

DICOM CONFORMANCE STATEMENT
FOR
CANON DIGITAL RADIOGRAPHY SYSTEM

ASTX-I9000
MODEL UDR-10A
(V2.5 SP0000 OR LATER)

CANON MEDICAL SYSTEMS CORPORATION

Trademarks

DICOM® is the registered trademark of the National Electrical Manufacturers Association for its Standards publications relating to digital communications of medical information.

This document may include trademarks or registered trademarks of their respective owners.

IMPORTANT!

- (1) No part of this document may be copied or reprinted, in whole or in part, without written permission.
- (2) The contents of this document are subject to change without prior notice and without our legal obligation.
- (3) Please refer to the Canon Medical Systems Corporation website for the most recent version of this conformance statement.

Global: <https://www.medical.canon/Interoperability/DICOM/EN>

Japan: <https://www.medical.canon/Interoperability/DICOM/JP>

1. CONFORMANCE STATEMENT OVERVIEW

Table 1-1 provides an overview of the network services supported by UDR-10A.

**Table 1-1
NETWORK SERVICES**

SOP Classes	User of Service (SCU)	Provider of Service (SCP)
Transfer		
X-Ray Radiofluoroscopic Image Storage	Yes	Yes
X-Ray Angiographic Image Storage	Yes	Yes
Computed Radiography Image Storage	Yes	Yes
Digital X-Ray Image Storage - For Presentation	Yes	Yes
Secondary Capture Image Storage	Yes	Yes
X-Ray Radiation Dose SR Storage	Yes	No
Storage Commitment		
Storage Commitment Push Model	Yes	No
Query/Retrieve		
Study Root Q/R Information Model - FIND	Yes	No
Study Root Q/R Information Model - MOVE	Yes	No
Workflow Management		
Storage Commitment Push Model	Yes	No
Modality Worklist Information Model - FIND	Yes	No
Modality Performed Procedure Step	Yes	No
Print Management		
Basic Grayscale Print Management	Yes	No
Verification		
Verification	Yes	Yes

Table 1-2 provides an overview of the media storage application profiles supported by UDR-10A.

**Table 1-2
MEDIA SERVICES**

SOP Classes	Write Files (FSC)	Update Files (FSU)	Read Files (FSR)
Compact Disk - Recordable			
General Purpose CD-R Interchange	Yes	No	No
DVD - Recordable			
General Purpose DVD-R Interchange	Yes	No	No
USB Media			
General Purpose USB Media Interchange	Yes	No	No

2. TABLE OF CONTENTS

1.	CONFORMANCE STATEMENT OVERVIEW	i
2.	TABLE OF CONTENTS	a
3.	INTRODUCTION	1
3.1	REVISION HISTORY	1
3.2	AUDIENCE.....	1
3.3	REMARKS	1
3.4	DEFINITIONS, TERMS AND ABBREVIATIONS	2
3.5	REFERENCES.....	3
4.	NETWORKING.....	4
4.1	IMPLEMENTATION MODEL.....	4
4.1.1	Application Data Flow	4
4.1.2	Functional Definition of AEs.....	6
4.1.3	Sequencing of Real-World Activities.....	8
4.2	AE SPECIFICATIONS	9
4.2.1	Storage SCU AE Specification.....	9
4.2.2	Storage Commitment SCU AE Specification	12
4.2.3	MWM SCU AE Specification.....	18
4.2.4	MPPS SCU AE Specification	26
4.2.5	Q/R SCU AE Specification.....	32
4.2.6	Storage SCP AE Specification.....	38
4.2.7	Print SCU AE Specification.....	42
4.2.8	Verification SCU AE Specification	52
4.2.9	Verification SCP AE Specification.....	55
4.3	NETWORK INTERFACES.....	58
4.3.1	Physical Network Interface	58
4.3.2	Additional Protocols	58
4.4	CONFIGURATION	59
4.4.1	AE Title/Presentation Address Mapping.....	59
4.4.2	Parameters.....	60
5.	MEDIA INTERCHANGE.....	62
5.1	IMPLEMENTATION MODEL.....	62
5.1.1	Application Data Flow	62
5.1.2	Functional Definition of AE.....	62
5.1.3	Sequencing of Real-World Activities.....	63
5.1.4	File Meta Information for Implementation Class and Version.....	63
5.2	AE SPECIFICATIONS	64
5.2.1	Offline-Media AE Specification	64
5.3	AUGMENTED AND PRIVATE APPLICATION PROFILES.....	65
5.3.1	Augmented Application Profiles.....	65
5.3.2	Private Application Profiles	65
5.4	MEDIA CONFIGURATION	65
6.	SUPPORT OF CHARACTER SETS.....	66
7.	SECURITY.....	67
7.1	DICOM Security Profile Availability.....	67

7.1.1 Secure Transport Connection Profiles67

8. ANNEXES68

8.1 IOD CONTENTS68

8.1.1 Created SOP Instances68

8.1.2 Usage of Attributes from received IOD's.....86

8.1.3 Attribute Mapping86

8.1.4 Coerced/Modified Fields87

8.1.5 Structured Report Document Information88

8.2 GRAYSCALE IMAGE CONSISTENCY93

8.3 STANDARD EXTENDED/SPECIALIZED/PRIVATE SOP CLASSES93

8.4 PRIVATE TRANSFER SYNTAXES.....93

8.5 DICOM Security Profile Details94

8.5.1 Secure Transport Connection Details94

3. INTRODUCTION

3.1 REVISION HISTORY

Table 3.1-1 Revision History

REV.	Date of Issue	Author	Description
	Jun, 2021	Canon Medical Systems	Initial Version
*A	Feb, 2023	Canon Medical Systems	For Software Version V2.5 SP0000 - Correct wrong SOP Class UID - Add Explicit VR Little Endian for X-Ray Radiation Dose SR - Add some attributes to MWM / MPPS - Add support of Secure transport profile and its configuration - Add notes to Support of character sets - Add/update attributes to some modules in created SOP Instances - Add TID10003B to X-Ray Radiation Dose Report

3.2 AUDIENCE

This document is intended for hospital staff, health system integrators, software designers or implementers. It is assumed that the reader has a working understanding of DICOM.

3.3 REMARKS

DICOM, by itself, does not guarantee interoperability. However, the Conformance Statement facilitates a first-level validation for interoperability between different applications supporting the same DICOM functionality.

This Conformance Statement is not intended to replace validation with other DICOM equipment to ensure proper exchange of information intended.

The scope of this Conformance Statement is to facilitate communication with Canon Medical Systems and other vendors' Medical equipment. The Conformance Statement should be read and understood in conjunction with the DICOM Standard [DICOM]. However, by itself it is not guaranteed to ensure the desired interoperability and a successful interconnectivity.

The user should be aware of the following important issues:

- The comparison of different conformance statements is the first step towards assessing interconnectivity between Canon Medical Systems and non- Canon Medical Systems equipment.
- Test procedures should be defined to validate the desired level of connectivity.
- The DICOM standard will evolve to meet the users' future requirements. Canon Medical Systems is actively involved in developing the standard further and therefore reserves the right to make changes to its products or to discontinue its delivery.

3.4 DEFINITIONS, TERMS AND ABBREVIATIONS

Definitions, terms and abbreviations used in this document are defined within the different parts of the DICOM standard.

Abbreviations and terms are as follows:

AE	Application Entity
ACSE	Application Control Service Element
AET	Application Entity Title
BCP195	Recommendations for Secure User of TLS and DTLS
CD-R	Compact Disc Recordable
CR	Computed Radiography
DER	Distinguished Encoding Rules
DIMSE	DICOM Message Service Element
DTLS	Datagram Transport Layer Security
DVD	A trademark of the DVD Forum that is not an abbreviation
DVD-R	DVD Recordable
DX	Digital X-ray
FSC	File-Set Creator
FSU	File-Set Updater
FSR	File-Set Reader
IE	Information Entity
IOD	Information Object Definition
IPv4	Internet Protocol version 4
IPv6	Internet Protocol version 6
IR	International Register of Coded Character Sets To Be Used With Escape Sequences
ISO	International Standard Organization
MPPS	Modality Performed Procedure Step
MSPS	Modality Scheduled Procedure Step
MWM	Modality Worklist Management
R	Required Key Attribute
O	Optional Key Attribute
PDU	Protocol Data Unit
PEM	(Privacy-enhanced Electronic Mail) Base64 encoded DER certificate
Q/R	Query/Retrieve
RF	Radiofluoroscopy
SCU	Service Class User (DICOM client)
SCP	Service Class Provider (DICOM server)
SOP	Service-Object Pair
SR	Structured Reporting
TCP/IP	Transmission Control Protocol/Internet Protocol
TLS	Transport Layer Security
U	Unique Key Attribute

UID	Unique Identifier
USB	Universal Serial Bus
XA	X-ray Angiography

3.5 REFERENCES

[DICOM] Digital Imaging and Communications in Medicine (DICOM),

4. NETWORKING

4.1 IMPLEMENTATION MODEL

4.1.1 Application Data Flow

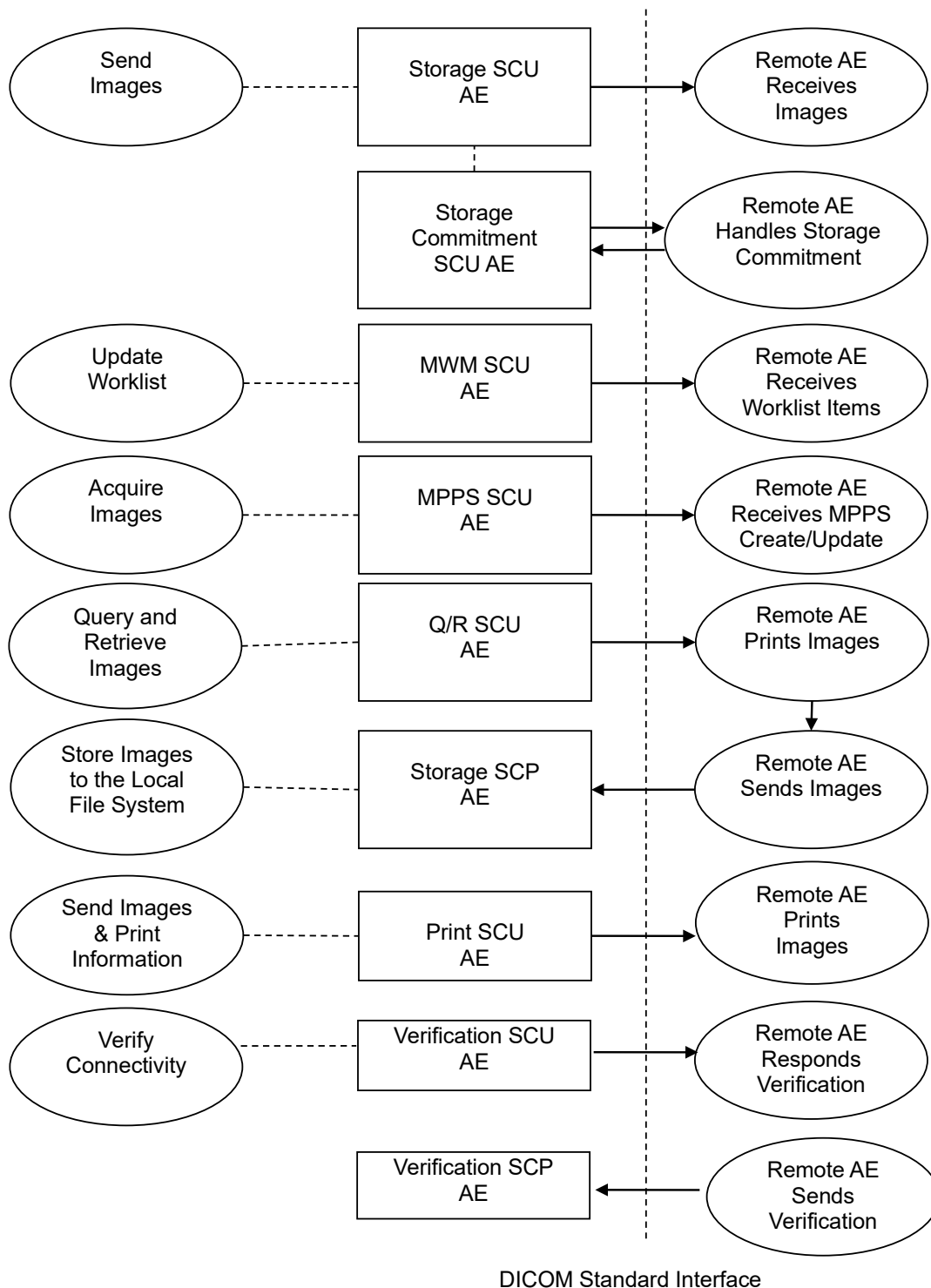

Figure 4.1-1
APPLICATION DATA FLOW DIAGRAM FOR NETWORKING

- The Storage SCU AE sends images to a remote AE. It is associated with the local real-world activity "Send Images". "Send Images" is performed upon user request for specific images selected or automatically after acquisition of image or completion of study. If the remote AE is configured as an archive device, the Storage SCU AE will send a storage commitment request to the Storage Commitment SCU AE.
- Receiving the storage commitment request from the Storage SCU AE, the Storage Commitment SCU AE will request Storage Commitment and if a commitment is successfully obtained will record this information in the local database.
- The MWM SCU AE receives Worklist information from a remote AE. It is associated with the local real-world activity "Update Worklist". When the "Update Worklist" is performed the MWM SCU AE queries a remote AE for worklist items and provides the set of worklist items matching the query request. "Update Worklist" is performed manually or automatically.
- The MPPS SCU AE sends MPPS information to a remote AE. It is associated with the local real-world activity "Acquire Images". When the "Acquire Images" is performed the MPPS SCU AE creates and updates Modality Performed Procedure Step instances managed by a remote AE. Acquisition of images will result in automated creation of an MPPS Instance. Completion of the MPPS is performed as the result of an operator action.
- The Q/R SCU AE queries a remote AE for lists of studies and series and retrieves selected studies and series. It is associated with the local real-world activity "Query and Retrieve Images".
- The Storage SCP AE receives incoming images. It is associated with the local real-world activity "Store Images to the Local File System". "Store Images to the Local File System" stores the received images to the local file system.
- The Print SCU AE prints images on a remote AE (Printer). It is associated with the local real-world activity "Send Images & Print Management Information". "Send Images & Print Management Information" creates a print-job within the print queue containing one or more virtual film sheets composed from images selected by the user.
- The Verification SCU AE issues a C-ECHO to verify a DICOM connection to a remote AE. It is associated with the local real-world activity "Verify Connectivity". "Verify Connectivity" is performed upon user request to verify the connectivity to a remote AE.
- The Verification SCP AE responds to C-ECHO requests.

4.1.2 Functional Definition of AEs

4.1.2.1 Functional Definition of Storage SCU AE

The existence of a send-job queue entry with associated network destination will activate the Storage SCU AE. An Association request is sent to the destination AE and upon successful negotiation of a Presentation Context the image transfer is started. If the remote AE is configured as an archive device, the storage SCU AE will send a storage commitment request to the Storage Commitment SCU AE.

4.1.2.2 Functional Definition of Storage Commitment SCU AE

Receiving the storage commitment request from the Storage SCU AE, the Storage Commitment SCU AE will request Storage Commitment and if a commitment is successfully obtained will record this information in the local database

4.1.2.3 Functional Definition of MWM SCU AE

The MWM SCU AE attempts to download a worklist from a remote node. If the MWM SCU AE establishes an Association to a remote AE, it will transfer patient's information and worklist items via the open Association. The results will be displayed in a separate list. The patient's information will be used for the patient registration.

4.1.2.4 Functional Definition of MPPS SCU AE

The MPPS SCU AE performs the creation of an MPPS Instance automatically when the user starts a worklist item and start the acquisition. Further updates on the MPPS data can be performed when the user completes the acquisition.

4.1.2.5 Functional Definition of Q/R SCU AE

The Q/R SCU AE is activated when the user enters Matching Key(e.g .Patient ID). The user can select studies, series to be retrieved. The images will be received at the Storage SCP AE.

4.1.2.6 Functional Definition of Storage SCP AE

The Storage SCP AE waits for another application to connect at the presentation address configured for its Application Entity Title. The Storage SCP AE will accept Associations with Presentation Contexts for SOP Classes of the Verification and Storage Service Classes. Any images received on such Presentation Contexts will be stored to the local file system.

4.1.2.7 Functional Definition of Print SCU AE

The existence of a print-job in the print queue will activate the Print SCU AE. An Association is established with the printer and the printer's status determined. If the printer is operating normally, the film sheets described within the print-job will be printed.

If the printer is not operating normally, the Print SCU AE will retry this print-job automatically.

4.1.2.8 Functional Definition of Verification SCU AE

The verification SCU AE issues a C-ECHO to verify a DICOM connection to a remote AE. It is performed upon user request.

The verification SCU AE also periodically attempts to initiate an association for life check to all configured remote SCPs, but does not issue a C-ECHO.

4.1.2.9 Functional Definition of Verification SCP AE

The Verification SCP AE waits for another application to connect at the presentation address configured for its Application Entity Title. The Verification SCP AE will accept Associations with Presentation Contexts for SOP Classes of the Verification and Storage Service Classes. After responding C-ECHO request, the Verification SCP AE updates the local operational status of the remote Application Entity requested.

4.1.3 Sequencing of Real-World Activities

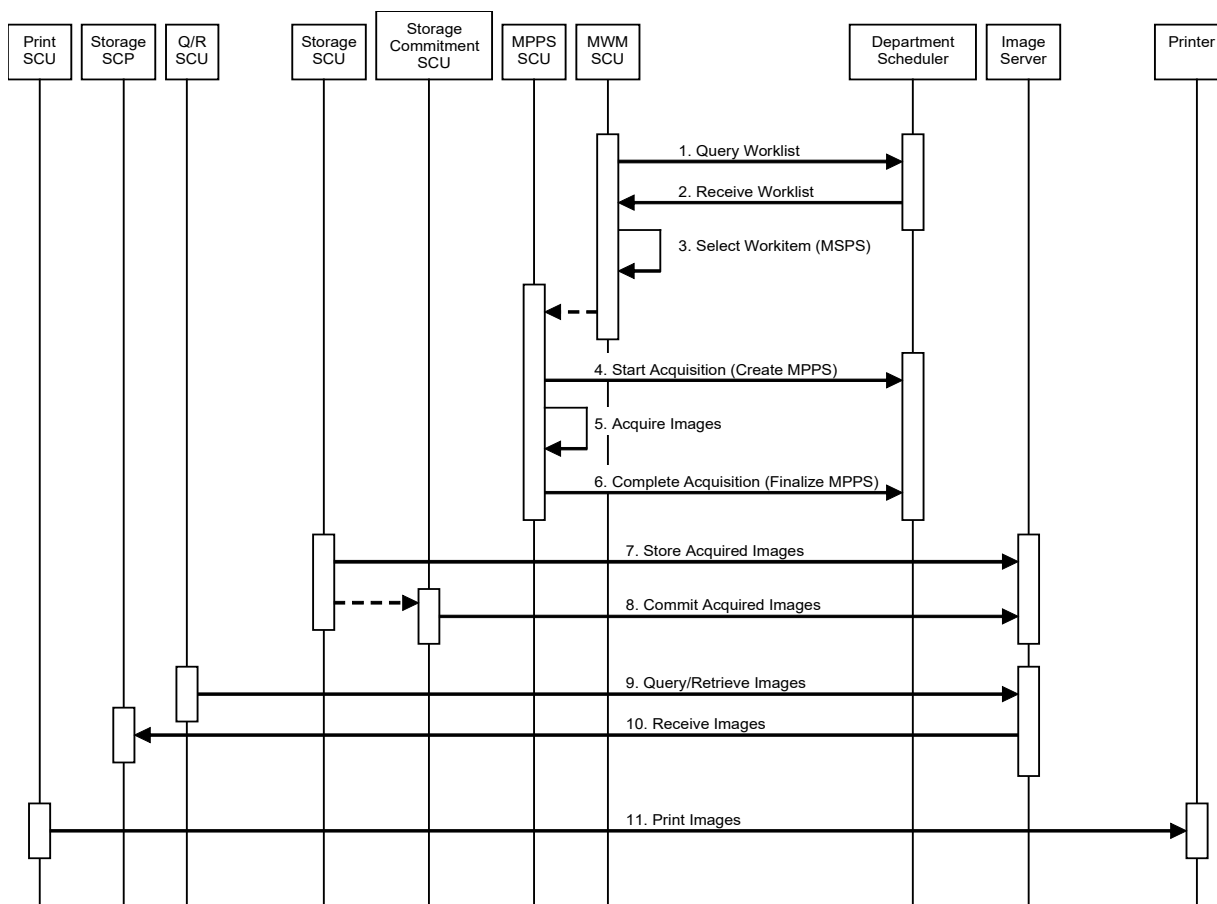

**Figure 4.1-2
SEQUENCING CONSTRAINTS**

Under typical scheduled workflow conditions the sequencing constraints illustrated in Figure 4.1-2 apply:

1. Query Worklist
2. Receive Worklist of Modality Scheduled Procedure Steps (MSPS)
3. Select Workitem (MSPS) from Worklist
4. Start Acquisition and Create MPPS
5. Acquire Images
6. Complete Acquisition and Finalize MPPS
7. Store Acquired Images
8. Commit Acquired Images
9. Query/Retrieve Images
10. Receive Images
11. Print Images

Other workflow situations (e.g. unscheduled procedure steps) will have other sequencing constraints. Some activities may be omitted according to situations.

4.2 AE SPECIFICATIONS

4.2.1 Storage SCU AE Specification

4.2.1.1 SOP Classes

The Storage SCU AE provides Standard Conformance to the following SOP Classes:

Table 4.2-1
SOP CLASSES FOR THE STORAGE SCU AE

SOP Class Name	SOP Class UID	SCU	SCP
X-Ray Angiographic Image Storage	1.2.840.10008.5.1.4.1.1.12.1	Yes	No
X-Ray Radiofluoroscopic Image Storage	1.2.840.10008.5.1.4.1.1.12.2	Yes	No
Digital X-Ray Image Storage - For Presentation	1.2.840.10008.5.1.4.1.1.1.1	Yes	No
Computed Radiography Image Storage	1.2.840.10008.5.1.4.1.1.1	Yes	No
Secondary Capture Image Storage	1.2.840.10008.5.1.4.1.1.7	Yes	No
X-Ray Radiation Dose SR Storage	1.2.840.10008.5.1.4.1.1.88.67	Yes	No

4.2.1.2 Association Policies

4.2.1.2.1 General

The DICOM standard application context name for DICOM 3.0 is always proposed:

Table 4.2-2
DICOM APPLICATION CONTEXT FOR THE STORAGE SCU AE

Application Context Name	1.2.840.10008.3.1.1.1
--------------------------	-----------------------

4.2.1.2.2 Number of Associations

The Storage SCU AE can initiate one Association at a time for each destination to which a transfer request is being processed in the active job queue list. Only one job will be active at a time, the other remains pending until the active job is completed or failed.

Table 4.2-3
NUMBER OF ASSOCIATIONS INITIATED FOR THE STORAGE SCU AE

Maximum number of simultaneous Associations	1
---	---

4.2.1.2.3 Asynchronous Nature

The Storage SCU AE does not support asynchronous communication (multiple outstanding transactions over a single Association).

Table 4.2-4
ASYNCHRONOUS NATURE FOR THE STORAGE SCU AE

Maximum number of outstanding asynchronous transactions	1
---	---

4.2.1.2.4 Implementation Identifying Information

The implementation information for the Storage SCU AE is:

**Table 4.2-5
DICOM IMPLEMENTATION CLASS AND VERSION FOR THE STORAGE SCU AE**

Implementation Class UID	1.2.392.200036.9116.32.5
Implementation Version Name	UDR10A

4.2.1.3 Association Initiation Policy

4.2.1.3.1 Activity - Send Images

4.2.1.3.1.1 Description and Sequencing of Activities

The Storage SCU AE attempts to initiate a new Association in order to issue a Storage request (C-STORE).

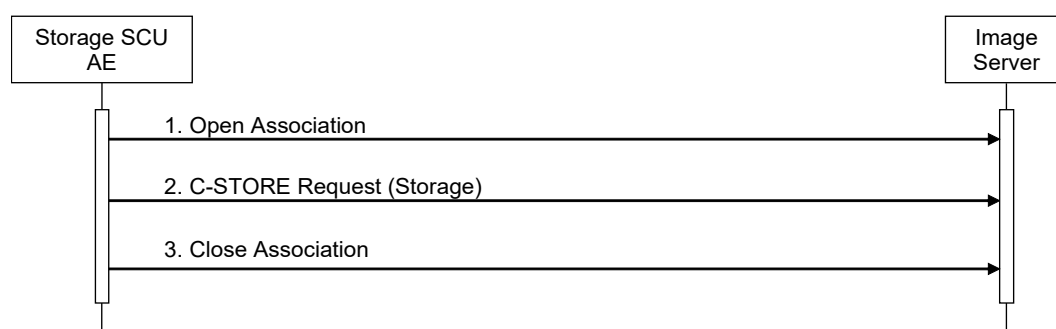

**Figure 4.2-1
SEQUENCING OF ACTIVITY - SEND IMAGES**

A possible sequence of interactions between the Storage SCU AE and an Image Server (e.g. a storage or archive device supporting the Storage SOP Classes as an SCP) is illustrated in the Figure above:

1. The Storage SCU AE opens an Association with the Image Server
2. Acquired images are transmitted to the Image Server using a Storage request (C-STORE) and the Image Server replies with a C-STORE response (status success).
3. The Storage SCU AE closes the Association with the Image Server.

4.2.1.3.1.2 Proposed Presentation Contexts

The Storage SCU AE is capable of proposing the Presentation Contexts shown in the following table:

**Table 4.2-6
PROPOSED PRESENTATION CONTEXTS FOR ACTIVITY SEND IMAGES**

Presentation Context Table					
Abstract Syntax		Transfer Syntax		Role	Ext. Neg.
Name	UID	Name List	UID List		
X-Ray Radiofluoroscopic Image Storage	1.2.840.10008.5.1.4 .1.1.12.2	Implicit VR Little Endian	1.2.840.10008.1.2	SCU	None
		Explicit VR Little Endian	1.2.840.10008.1.2.1		
X-Ray Angiographic Image Storage	1.2.840.10008.5.1.4 .1.1.12.1	Implicit VR Little Endian	1.2.840.10008.1.2	SCU	None
		Explicit VR Little Endian	1.2.840.10008.1.2.1		

Computed Radiography Image Storage	1.2.840.10008.5.1.4 .1.1.1	Implicit VR Little Endian Explicit VR Little Endian	1.2.840.10008.1.2 1.2.840.10008.1.2.1	SCU	None
Digital X-Ray Image Storage - For Presentation	1.2.840.10008.5.1.4 .1.1.1.1	Implicit VR Little Endian Explicit VR Little Endian	1.2.840.10008.1.2 1.2.840.10008.1.2.1	SCU	None
Secondary Capture Image Storage	1.2.840.10008.5.1.4 .1.1.7	Implicit VR Little Endian Explicit VR Little Endian	1.2.840.10008.1.2 1.2.840.10008.1.2.1	SCU	None
X-Ray Radiation Dose SR Storage	1.2.840.10008.5.1.4 .1.1.88.67	Implicit VR Little Endian Explicit VR Little Endian	1.2.840.10008.1.2 1.2.840.10008.1.2.1	SCU	None

4.2.1.3.1.3 SOP Specific Conformance for Storage SOP Classes

The Storage SCU AE provides standard conformance to the Storage Service Class as an SCU.

The behavior of Storage SCU AE when encountering status codes in a C-STORE response is summarized in the table below:

**Table 4.2-7
STORAGE C-STORE RESPONSE STATUS HANDLING BEHAVIOR**

Service Status	Further Meaning	Status Code	Behavior
Success	Success	0000	The SCP has successfully stored the SOP Instance. If all SOP Instances in a send job have status success then the job is marked as complete.
Refused	Out of Resources	A7xxH	The Association is aborted, and the send job is marked as failed. The status meaning is logged and the job failure is reported to the user via the job control application.
Error	Data Set does not match SOP Class	A9xxH	
Error	Cannot Understand	CxxxH	
Warning	Coercion of Data Elements	B000H	
Warning	Data Set does not match SOP Class	B007H	
Warning	Elements Discarded	B006H	
*	*	Any other status codes.	

The behavior of Storage SCU AE during communication failure is summarized in the table below:

**Table 4.2-8
STORAGE COMMUNICATION FAILURE BEHAVIOR**

Exception	Behavior
Timeout	The Association is aborted, and the send job is marked as failed. The reason is logged and the job failure is reported to the user via the job control application.
Association aborted by the SCP or network layers	The send job is marked as failed. The reason is logged and the job failure is reported to the user via the job control application.

If the image transfer fails, the Storage SCU AE will retry this send-job automatically. The user is able to cancel the send-jobs.

The contents of Image Storage SOP Instances created by the Storage SCU AE conform to the DICOM Image IOD definitions and are described in section 8.1.

4.2.2 Storage Commitment SCU AE Specification

4.2.2.1 SOP Classes

The Storage Commitment SCU AE provides Standard Conformance to the following SOP Classes:

Table 4.2-9
SOP CLASSES FOR THE STORAGE COMMITMENT SCU AE

SOP Class Name	SOP Class UID	SCU	SCP
Storage Commitment Push Model	1.2.840.10008.1.20.1	Yes	No

4.2.2.2 Association Policies

4.2.2.2.1 General

The DICOM standard application context name for DICOM 3.0 is always proposed:

Table 4.2-10
DICOM APPLICATION CONTEXT FOR THE STORAGE COMMITMENT SCU AE

Application Context Name	1.2.840.10008.3.1.1.1
--------------------------	-----------------------

4.2.2.2.2 Number of Associations

The Storage Commitment SCU AE initiates one Association at a time.

Table 4.2-11
NUMBER OF ASSOCIATIONS INITIATED FOR THE STORAGE COMMITMENT SCU AE

Maximum number of simultaneous Associations	1
---	---

The Storage Commitment SCU AE accepts Associations to receive N-EVENT-REPORT notifications for the Storage Commitment Push Model SOP Class.

Table 4.2-12
NUMBER OF ASSOCIATIONS ACCEPTED FOR THE STORAGE COMMITMENT SCU AE

Maximum number of outstanding asynchronous transactions	1
---	---

4.2.2.2.3 Asynchronous Nature

The Storage Commitment SCU AE does not support asynchronous communication (multiple outstanding transactions over a single Association).

Table 4.2-13
ASYNCHRONOUS NATURE FOR THE STORAGE COMMITMENT SCU AE

Maximum number of outstanding asynchronous transactions	1
---	---

4.2.2.2.4 Implementation Identifying Information

The implementation information for the Storage Commitment SCU AE is:

Table 4.2-14
DICOM IMPLEMENTATION CLASS AND VERSION FOR THE STORAGE COMMITMENT SCU AE

Implementation Class UID	1.2.392.200036.9116.32.5
Implementation Version Name	UDR10A

4.2.2.3 Association Initiation Policy

4.2.2.3.1 Activity - Commit Sent Images

4.2.2.3.1.1 Description and Sequencing of Activities

If the remote AE is configured as an archive device, the Storage Commitment SCU AE will, after all images have been sent, transmit a single storage commitment request(N-ACTION). Upon receiving the N-ACTION response the Storage Commitment SCU AE will release the Association. The notification of Storage commitment (N-EVENT-REPORT) will be received over a separate Association.

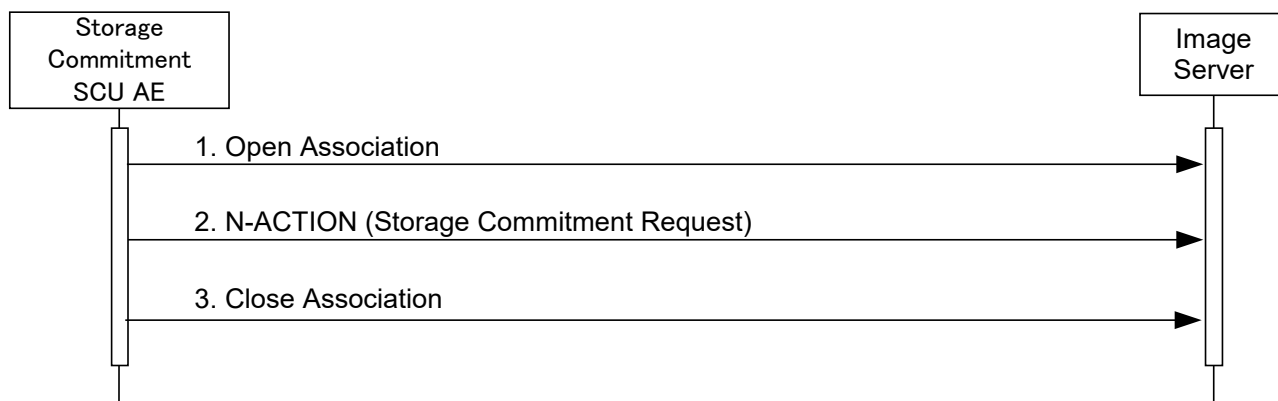

Figure 4.2-2
SEQUENCING OF ACTIVITY - COMMIT SENT IMAGES

A possible sequence of interactions between the Storage Commitment SCU AE and an Image Server (e.g. a storage or archive device supporting the Storage Commitment SOP Classes as an SCP) is illustrated in the Figure above:

1. The Storage Commitment SCU AE opens an Association with the Image Server.
2. A Storage Commitment request (N-ACTION) is transmitted to the Image Server to obtain Storage Commitment of previously transmitted images. The Image Server replies with an N-ACTION response indicating the request has been received and is being processed.
3. The Storage Commitment SCU AE closes the Association with the Image Server.

NOTE: The N-EVENT-REPORT will be sent over a separate Association initiated by the Image Server (see Section 4.2.2.4.1).

4.2.2.3.1.2 Proposed Presentation Contexts

The Storage Commitment SCU AE is capable of proposing the Presentation Contexts shown in the following table:

**Table 4.2-15
PROPOSED PRESENTATION CONTEXTS FOR ACTIVITY COMMIT SENT IMAGES**

Presentation Context Table					
Abstract Syntax		Transfer Syntax		Role	Ext. Neg.
Name	UID	Name List	UID List		
Storage Commitment Push Model	1.2.840.10008.1.20.1	Implicit VR Little Endian	1.2.840.10008.1.2	SCU	None
		Explicit VR Little Endian	1.2.840.10008.1.2.1		

A Presentation Context for the Storage Commitment Push Model will only be proposed if the remote AE is configured as an archive device.

4.2.2.3.1.3 SOP Specific Conformance for Storage Commitment SOP Class

4.2.2.3.1.3.1 Storage Commitment Operations (N-ACTION)

The Storage Commitment SCU AE provides standard conformance to the Storage Commitment Service Class as an SCU.

The Storage Commitment SCU AE will send Storage Commitment for instances of the Storage SOP Classes if the remote AE is configured as an archive device and a presentation context for the Storage Commitment Push Model has been accepted.

The behavior of Storage Commitment SCU AE when encountering status codes in an N-ACTION response is summarized in the Table below:

**Table 4.2-16
STORAGE COMMITMENT N-ACTION RESPONSE STATUS HANDLING BEHAVIOR**

Service Status	Further Meaning	Status Code	Behavior
Success	Success	0000	The request for storage commitment is considered successfully sent.
*	*	Any other status code.	The Association is aborted and the status is logged and the job incompleteness is reported to the user via the database management application. The Storage Commitment SCU AE will retry the request next time the system start-up.

The behavior of Storage Commitment AE during communication failure is summarized in the Table below:

**Table 4.2-17
STORAGE COMMITMENT COMMUNICATION FAILURE BEHAVIOR**

Exception	Behavior
Timeout	The Association is aborted and the status is logged and the job incompleteness is reported to the user via the database management application. The Storage Commitment SCU AE will retry the request next time the system start-up.
Association aborted by the SCP or network layers	The status is logged and the job incompleteness is reported to the user via the database management application. The Storage Commitment SCU AE will retry the request next time the system start-up.

4.2.2.4 Association Acceptance Policy

4.2.2.4.1 Activity - Receive Storage Commitment Response

4.2.2.4.1.1 Description and Sequencing of Activities

The Storage Commitment SCU AE will accept Associations in order to receive responses to a Storage Commitment Request.

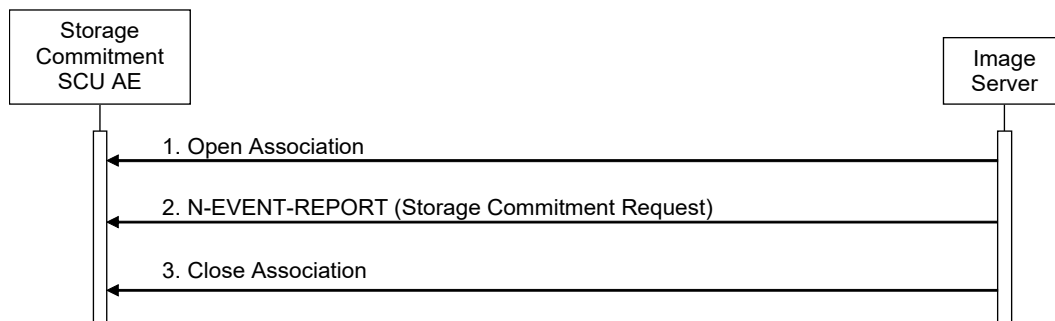

Figure 4.2-3
SEQUENCING OF ACTIVITY - RECEIVE STORAGE COMMITMENT RESPONSE

A possible sequence of interactions between the Storage Commitment SCU AE and an Image Server (e.g. a storage or archive device supporting Storage Commitment SOP Classes as an SCP) is illustrated in the Figure above:

1. The Image Server opens an association with the Storage Commitment SCU AE.
2. The Image Server sends an N-EVENT-REPORT request notifying the Storage Commitment SCU AE of the status of a previous Storage Commitment Request. The Storage Commitment SCU AE replies with an N-EVENT-REPORT response confirming receipt.
3. The Image Server closes the association with the Storage Commitment SCU AE.

The Storage Commitment SCU AE may reject Association attempts as shown in the Table below. The Result, Source and Reason/Diag columns represent the values returned in the appropriate fields of an ASSOCIATE-RJ PDU (see PS 3.8, Section 9.3.4).

**Table 4.2-18
ASSOCIATION REJECTION REASONS**

Result	Source	Reason/Diag	Explanation
2 - rejected-transient	DICOM UL service-provider (Presentation related function)	2 - local-limit-exceeded	The (configurable) maximum number of simultaneous Associations has been reached. An Association request with the same parameters may succeed at a later time.
2 - rejected-transient	DICOM UL service-provider (ACSE related function)	1 - no-reason-given	The Association request could not be parsed. An Association request with the same format may succeed at a later time.
1 - rejected-permanent	DICOM UL service-user	2 - application-context-name-not-supported	The Association request contained an unsupported Application Context Name. An association request with the same parameters will not succeed at a later time.
1 - rejected-permanent	DICOM UL service-user	7 - called-AE-title-not-recognized	The Association request contained an unrecognized Called AE Title. An Association request with the same parameters will not succeed at a later time unless configuration changes are made. This rejection reason normally occurs when the Association initiator is incorrectly configured and attempts to address the Association acceptor using the wrong AE Title.
1 - rejected-permanent	DICOM UL service-user	3 - calling-AE-title-not-recognized	The Association request contained an unrecognized Calling AE Title. An Association request with the same parameters will not succeed at a later time unless configuration changes are made. This rejection reason normally occurs when the Association acceptor has not been configured to recognize the AE Title of the Association initiator.
1 - rejected-permanent	DICOM UL service-provider (ACSE related function)	1 - no-reason-given	The Association request could not be parsed. An Association request with the same format will not succeed at a later time.

4.2.2.4.1.2 Accepted Presentation Contexts

The Storage Commitment SCU AE will accept Presentation Contexts as shown in the Table below.

**Table 4.2-19
ACCEPTABLE PRESENTATION CONTEXTS FOR
ACTIVITY RECEIVE STORAGE COMMITMENT RESPONSE**

Presentation Context Table					
Abstract Syntax		SOP Class UID		Role	Ext. Neg.
Name	UID	Name List	UID List		
Storage Commitment Push Model	1.2.840.10008.1.20.1	Implicit VR Little Endian Explicit VR Little Endian	1.2.840.10008.1.2 1.2.840.10008.1.2.1	SCU	None

4.2.2.4.1.3 SOP Specific Conformance for Storage Commitment SOP Class

4.2.2.4.1.3.1 Storage Commitment Notifications (N-EVENT-REPORT)

The Storage Commitment SCU AE provides standard conformance to the Storage Commitment Service Class as an SCU.

The behavior of Storage Commitment SCU AE when receiving Event Types within the N-EVENT-REPORT is summarized in the Table below.

**Table 4.2-20
STORAGE COMMITMENT N-EVENT-REPORT BEHAVIOR**

Event Type Name Event	Type ID	Behavior
Storage Commitment Request Successful	1	The Storage Commitment SCU AE permits the operator(s) to delete the Referenced SOP Instances under Referenced SOP Sequence (0008,1199). Also successfully committed SOP Instances are candidates for automatic deletion from the local database if local resources become scarce.
Storage Commitment Request Complete - Failures Exist	2	The Referenced SOP Instances under Referenced SOP Sequence (0008,1199) are treated in the same way as in the success case (Event Type 1). The Referenced SOP Instances under Failed SOP Sequence (0008,1198) are marked within the database as Commitment Failure. The Failure Reasons are logged and the job incompleteness is reported to the user via the database management application. The Storage Commitment SCU AE will retry the request next time the system start-up.

The reasons for returning specific status codes in an N-EVENT-REPORT response are summarized in the Table below.

**Table 4.2-21
STORAGE COMMITMENT N-EVENT-REPORT RESPONSE STATUS REASONS**

Service Status	Further Meaning	Status Code	Reasons
Success	Success	0000	The storage commitment result has been successfully received.

4.2.3 MWM SCU AE Specification

4.2.3.1 SOP Classes

The MWM SCU AE provides Standard Conformance to the following SOP Classes:

Table 4.2-22
SOP CLASSES FOR THE MWM SCU AE

SOP Class Name	SOP Class UID	SCU	SCP
Modality Worklist Information Model - FIND	1.2.840.10008.5.1.4.31	Yes	No

4.2.3.2 Association Policies

4.2.3.2.1 General

The DICOM standard application context name for DICOM 3.0 is always proposed:

Table 4.2-23
DICOM APPLICATION CONTEXT FOR THE MWM SCU AE

Application Context Name	1.2.840.10008.3.1.1.1
--------------------------	-----------------------

4.2.3.2.2 Number of Associations

The MWM SCU AE initiates one Association at a time for a Worklist request.

Table 4.2-24
NUMBER OF ASSOCIATIONS INITIATED FOR THE MWM SCU AE

Maximum number of simultaneous Associations	1
---	---

4.2.3.2.3 Asynchronous Nature

The MWM SCU AE does not support asynchronous communication (multiple outstanding transactions over a single Association).

Table 4.2-25
ASYNCHRONOUS NATURE FOR THE MWM SCU AE

Maximum number of outstanding asynchronous transactions	1
---	---

4.2.3.2.4 Implementation Identifying Information

The implementation information for this Application Entity is:

Table 4.2-26
DICOM IMPLEMENTATION CLASS AND VERSION FOR THE MWM SCU AE

Implementation Class UID	1.2.392.200036.9116.32.5
Implementation Version Name	UDR10A

4.2.3.3 Association Initiation Policy

4.2.3.3.1 Activity - Update Worklist

4.2.3.3.1.1 Description and Sequencing of Activities

The request for an "Update Worklist" is initiated by user interaction, (i.e. pressing the buttons "Get Worklist", reading Barcode) or automatically at the time of get Study information by polling.

Upon initiation of the request, the MWM SCU AE will build an Identifier for the C-FIND request, will initiate an Association to send the request and will wait for Worklist responses. After retrieval of all responses, the MWM SCU AE will access the local database to add or update study data. The results will be displayed in a separate list.

The MWM SCU AE will initiate an Association in order to issue a C-FIND request according to the Modality Worklist Information Model.

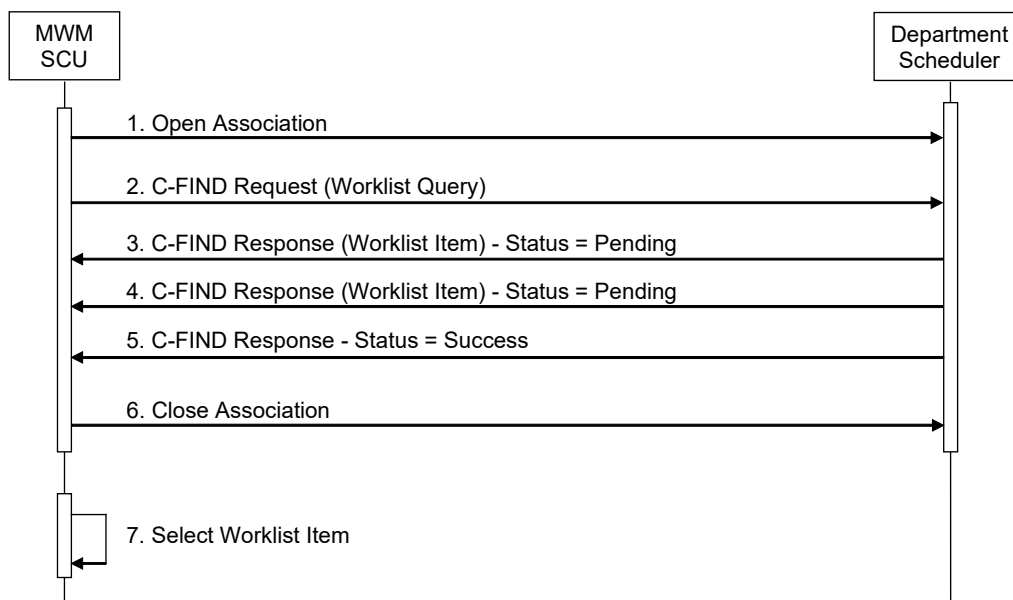

Figure 4.2-4
SEQUENCING OF ACTIVITY - UPDATE WORKLIST

A possible sequence of interactions between the MWM SCU AE and a Department Scheduler (e.g. a device such as a RIS or HIS which supports the Modality Worklist SOP Class as an SCP) is illustrated in the Figure above:

1. The MWM SCU AE opens an association with the Department Scheduler
2. The MWM SCU AE sends a C-FIND request to the Department Scheduler containing the Worklist Query attributes.
3. The Department Scheduler returns a C-FIND response containing the requested attributes of the first matching Worklist Item.
4. The Department Scheduler returns another C-FIND response containing the requested attributes of the second matching Worklist Item.
5. The Department Scheduler returns another C-FIND response with status Success indicating that no further matching Worklist Items exist. This example assumes that only 2 Worklist items match the Worklist Query.
6. The MWM SCU AE closes the association with the Department Scheduler.
7. The user selects a Worklist Item from the Worklist and prepares to acquire new images.

4.2.3.3.1.2 Proposed Presentation Contexts

The MWM SCU AE will propose Presentation Contexts as shown in the following table:

**Table 4.2-27
PROPOSED PRESENTATION CONTEXTS FOR ACTIVITY UPDATE WORKLIST**

Presentation Context Table					
Abstract Syntax		Transfer Syntax		Role	Ext. Neg.
Name	UID	Name List	UID List		
Modality Worklist Information Model - FIND	1.2.840.10008.5.1.4.31	Implicit VR Little Endian Explicit VR Little Endian	1.2.840.10008.1.2 1.2.840.10008.1.2.1	SCU	None

4.2.3.3.1.3 SOP Specific Conformance for Modality Worklist SOP Class

The MWM SCU AE provides standard conformance to the Modality Worklist SOP Class as an SCU.

The behavior of the MWM SCU when encountering status codes in a Modality Worklist C-FIND response is summarized in the table below.

**Table 4.2-28
MODALITY WORKLIST C-FIND RESPONSE STATUS HANDLING BEHAVIOUR**

Service Status	Further Meaning	Status Code	Behavior
Success	Matching is complete	0000	The SCP has completed the matches. Worklist items are available for display or further processing.
Refused	Out of Resources	A700H	The Association is aborted using A-ABORT and the worklist is empty. The status meaning is logged.
Failed	Identifier does not match SOP Class	A900H	
Failed	Unable to Process	CxxxH	
Cancel	Matching terminated due to Cancel request	FE00H	If the query was cancelled due to too many worklist items then the SCP has completed the matches. Worklist items are available for display or further processing. The status meaning is logged.
Pending	Matches are continuing	FF00H	The worklist item contained in the Identifier is collected for later display or further processing.
Pending	Matches are continuing - Warning that one or more Optional Keys were not supported	FF01H	
*	*	Any other status codes.	The Association is aborted using A-ABORT and the worklist is empty. The status meaning is logged.

The behavior of the MWM SCU AE during communication failure is summarized in the table below.

**Table 4.2-29
MODALITY WORKLIST COMMUNICATION FAILURE BEHAVIOR**

Exception	Behavior
Timeout	The Association is aborted using A-ABORT and the worklist is empty. The reason is logged.
Association aborted by the SCP or network layers	The worklist is empty and the reason is logged.

Acquired images will always use the Study Instance UID specified for the Scheduled Procedure Step (if available). If the specified study instance UID is not available, it will be generated locally. If an acquisition is unscheduled, a Study Instance UID will be generated locally.

The table below provides a description of the MWM SCU AE Worklist Request Identifier and specifies the attributes that are copied into the images. Unexpected attributes returned in a C-FIND response are ignored.

Table 4.2-30
WORKLIST REQUEST IDENTIFIER

Module Name Attribute Name	Tag	VR	M	R	Q	D	IOD
Scheduled Procedure Step							
Scheduled Procedure Step Sequence	(0040,0100)	SQ					
> Modality	(0008,0060)	CS	S	x			x
> Requested Contrast	(0032,1070)	LO					x
> Scheduled Station AE Title	(0040,0001)	AE	S				
> Scheduled Procedure Step Start Date	(0040,0002)	DA	S		x	x	
> Scheduled Procedure Step Start Time	(0040,0003)	TM		x			
> Scheduled Procedure Step End Date	(0040,0004)	DA					
> Scheduled Procedure Step End Time	(0040,0005)	TM					
> Scheduled Performing Physician's Name	(0040,0006)	PN		x			
> Scheduled Procedure Step Description	(0040,0007)	LO		x			x
> Scheduled Protocol Code Sequence	(0040,0008)	SQ					
>> Code value	(0008,0100)	SH		x			
>> Coding Scheme Designator	(0008,0102)	SH		x			
>> Coding Scheme Version	(0008,0103)	SH		x			
>> Code Meaning	(0008,0104)	LO		x			
> Scheduled Procedure Step ID	(0040,0009)	SH		x			
> Scheduled Station Name	(0040,0010)	SH	(S)	x			
> Scheduled Procedure Step Location	(0040,0011)	SH					
> Pre-Medication	(0040,0012)	LO					
> Scheduled Procedure Step Status	(0040,0020)	LO					
> Comments on the Scheduled Procedure Step	(0040,0400)	LT					
Requested Procedure							
Study Instance UID	(0020,000D)	UI	(S)	x			x
Requested Procedure Description	(0032,1060)	LO	(S)	x			
Referenced Study Sequence	(0008,1110)	SQ					
> Referenced SOP Class UID	(0008,1150)	SH		x			
> Referenced SOP Instance UID	(0008,1155)	SH		x			
Requested Procedure ID	(0040,1001)	SH	(S)	x			
Reason for the Requested Procedure	(0040,1002)	LO					
Requested Procedure Comments	(0040,1003)	SH					
Patient Transport Arrangements	(0040,1004)	LO					
Requested Procedure Location	(0040,1005)	LO					
Confidentiality Code	(0040,1008)	LO					
Reporting Priority	(0040,1009)	SH					
Names of Intended Recipients of Results	(0040,1010)	PN					
Requested Procedure Description	(0040,1064)	SQ					
>Code Value	(0008,0100)	SH					
>Coding Scheme Designator	(0008,0102)	SH					
>Coding Scheme Version	(0008,0103)	SH					
>Code Meaning	(0008,0104)	LO					
Requested Procedure Comments	(0040,1400)	LT					
Imaging Service Request							
Accession Number	(0008,0050)	SH	(S)	x	x	x	x
Referring Physician's Name	(0008,0090)	PN	(S)	x		x	x
Requesting Physician	(0032,1032)	PN					x
Requesting Service	(0032,1033)	LO					x
Admission ID	(0038,0010)	LO					x
Issuer of Admission ID	(0038,0011)	LO					x
Reason for the Imagin Service Request	(0040,2001)	LO					x
Issue Date of Imaging Service Request	(0040,2004)	DA					x
Issue Time of Imaging Service Request	(0040,2005)	TM					x

Module Name Attribute Name	Tag	VR	M	R	Q	D	IOD
Order Entered By	(0040,2008)	PN					x
Order Enterer's Location	(0040,2009)	SH					x
Order Callback Phone Number	(0040,2010)	SH					x
Order Callback Telecom Information	(0040,2011)	LO					x
Placer Order Number / Imaging Service Request	(0040,2016)	LO					x
Filler Order Number / Imaging Service Request	(0040,2017)	LO					x
Imaging Service Request Comments	(0040,2400)	LT					x
Visit Identification							
Institution Name	(0008,0080)	LO					x
Institution Address	(0008,0081)	ST					x
Institution Code Sequence	(0008,0082)	SQ					x
>Code Value	(0008,0100)	SH					x
>Coding Scheme Designator	(0008,0102)	SH					x
>Coding Scheme Version	(0008,0103)	SH					x
>Code Meaning	(0008,0104)	LO					x
Admission ID	(0038,0010)	LO					x
Issuer of Admission ID	(0038,0011)	LO					x
Visit Status							
Visit Status ID	(0038,0008)	CS					x
Current Patient Location	(0038,0300)	LO					x
Patient's Institution Residence	(0038,0400)	LO					x
Visit Comment	(0038,4000)	ST					x
Visit Relationship							
Referenced Patient Sequence	(0008,1120)	SQ					x
>Referenced SOP Class UID	(0008,1150)	UI					x
>Referenced SOP Instance UID	(0008,1155)	UI					x
Visit Admission							
Referring Physician's Address	(0008,0092)	ST					x
Referring Physician's Telephone Numbers	(0008,0094)	SH					x
Admission Diagnoses Description	(0008,1080)	LO					x
Admission Diagnoses Code Sequence	(0008,1084)	SQ					x
>Code Value	(0008,0100)	SH					x
>Coding Scheme Designator	(0008,0102)	SH					x
>Coding Scheme Version	(0008,0103)	SH					x
>Code Meaning	(0008,0104)	LO					x
Route of Admissions	(0038,0016)	LO					x
Admission Date	(0038,0020)	DA					x
Admission Time	(0038,0021)	TM					x
Patient Relationship							
Referenced Patient Alias Sequence	(0038,0004)	SQ					x
>Referenced SOP Class UID	(0008,1150)	UI					x
>Referenced SOP Instance UID	(0008,1155)	UI					x
Patient Identification							
Patient's Name	(0010,0010)	PN	(S)	x	x	x	x
Patient ID	(0010,0020)	LO	(S)	x	x	x	x
Issuer of Patient ID	(0010,0021)	LO					x
Other Patient IDs	(0010,1000)	LO					x
Other Patient Names	(0010,1001)	PN					x
Patient's Birth Name	(0010,1005)	PN					x
Patient's Mother's Birth Name	(0010,1060)	PN					x
Medical Record Locator	(0010,1090)	LO					x

Module Name Attribute Name	Tag	VR	M	R	Q	D	IOD
Patient Demographic							
Patient's Birth Date	(0010,0030)	DA	(S)	x		x	x
Patient's Birth Time	(0010,0032)	TM					x
Patient's Sex	(0010,0040)	CS	(S)	x		x	x
Patient's Insurance Plan Code Sequence	(0010,0050)	SQ					x
>Code Value	(0008,0100)	SH					x
>Coding Scheme Designator	(0008,0102)	SH					x
>Coding Scheme Version	(0008,0103)	SH					x
>Code Meaning	(0008,0104)	LO					x
Patient's Age	(0010,1010)	AS					x
Patient's Size	(0010,1020)	DS					x
Patient's Weight	(0010,1030)	DS					x
Patient's Address	(0010,1040)	LO					x
Military Rank	(0010,1080)	LO					x
Branch of Service	(0010,1081)	LO					x
Country of Residence	(0010,2150)	LO					x
Region of Residence	(0010,2152)	LO					x
Patient's Telephone Numbers	(0010,2154)	SH					x
Ethnic Group	(0010,2160)	SH					x
Patient's Religious Preference	(0010,21F0)	LO					x
Patient Comments	(0010,4000)	LT	(S)	x		x	x
Patient Medical							
Allergies	(0010,2110)	LO	(S)	x		x	x
Smoking Status	(0010,21A0)	CS					x
Additional Patient History((0010,21B0)	LT					x
Pregnancy Status	(0010,21C0)	US	(S)	x		x	x
Last Menstrual Date	(0010,21D0)	DA					x
Special Needs	(0038,0050)	LO	(S)	x		x	
Patient State	(0038,0500)	LO					x

The above table should be read as follows:

- Module Name: The name of the associated module for supported worklist attributes.
- Attribute Name: Attributes supported to build the MWM SCU AE Worklist Request Identifier.
- Tag: DICOM tag for this attribute.
- VR: DICOM VR for this attribute.
- M: Matching keys for (automatic) Worklist Update. An "S" will indicate that the MWM SCU AE will supply an attribute value for Single Value Matching. A "(S)" will indicate that NULL attribute value may be set by the user.
- R: Return keys. An "x" will indicate that the MWM SCU AE will supply this attribute as Return Key with zero length for Universal Matching.
- Q: Interactive Query Key. An "x" will indicate that the MWM SCU AE will supply this attribute as matching key, if entered in the Query Patient Worklist dialog.
- D: Displayed keys. An "x" indicates that this worklist attribute is displayed to the user during a patient selection. For example, Patient Name will be displayed when selecting the patient prior to an examination. The patient name may be abbreviated to about 15 characters depending on the display location.
- IOD: An "x" indicates that this Worklist attribute is included into all Object Instances created during performance of the related Procedure Step. All characters are output even for tags that are displayed with characters omitted when displayed.

Notes: Specific Character Set (0008,0005) will be created if an extended or replacement character set is used in the matching keys.

The default Query Configuration is set to "Modality" (RF), "Date" (date of today) and own AETitle.

If the modality code return value does not match the query key, the study cannot start.

4.2.3.4 Association Acceptance Policy

The MWM SCU AE does not accept Associations.

4.2.4 MPPS SCU AE Specification

4.2.4.1 SOP Classes

The MPPS SCU AE provides Standard Conformance to the following SOP Classes:

Table 4.2-31
SOP CLASSES FOR THE MPPS SCU AE

SOP Class Name	SOP Class UID	SCU	SCP
Modality Performed Procedure Step	1.2.840.10008.3.1.2.3.3	Yes	No

4.2.4.2 Association Policies

4.2.4.2.1 General

The DICOM standard application context name for DICOM 3.0 is always proposed:

Table 4.2-32
DICOM APPLICATION CONTEXT FOR THE MPPS SCU AE

Application Context Name	1.2.840.10008.3.1.1.1
--------------------------	-----------------------

4.2.4.2.2 Number of Associations

The MPPS SCU AE initiates one Association at a time.

Table 4.2-33
NUMBER OF ASSOCIATIONS INITIATED FOR THE MPPS SCU AE

Maximum number of simultaneous Associations	1
---	---

4.2.4.2.3 Asynchronous Nature

The MPPS SCU AE does not support asynchronous communication (multiple outstanding transactions over a single Association).

Table 4.2-34
ASYNCHRONOUS NATURE FOR THE MPPS SCU AE

Maximum number of outstanding asynchronous transactions	1
---	---

4.2.4.2.4 Implementation Identifying Information

The implementation information for this Application Entity is:

Table 4.2-35
DICOM IMPLEMENTATION CLASS AND VERSION FOR THE MPPS SCU AE

Implementation Class UID	1.2.392.200036.9116.32.5
Implementation Version Name	UDR10A

4.2.4.3 Association Initiation Policy

4.2.4.3.1 Activity - Acquire Images

4.2.4.3.1.1 Description and Sequencing of Activities

After the user selects Patient and starts the study, the MPPS SCU AE is awaiting the 1st acquisition of images. The trigger to create a MPPS SOP Instance is derived from this event. An Association to the configured MPPS SCP system is established immediately and the related MPPS SOP Instance will be created.

Further updates on the MPPS data can be performed when the user completes the study.

The MPPS SCU AE will initiate an Association to issue an:

- N-CREATE request according to the CREATE Modality Performed Procedure Step SOP Instance operation, or an:
- N-SET request to update the contents and state of the MPPS according to the SET Modality Performed Procedure Step Information operation.

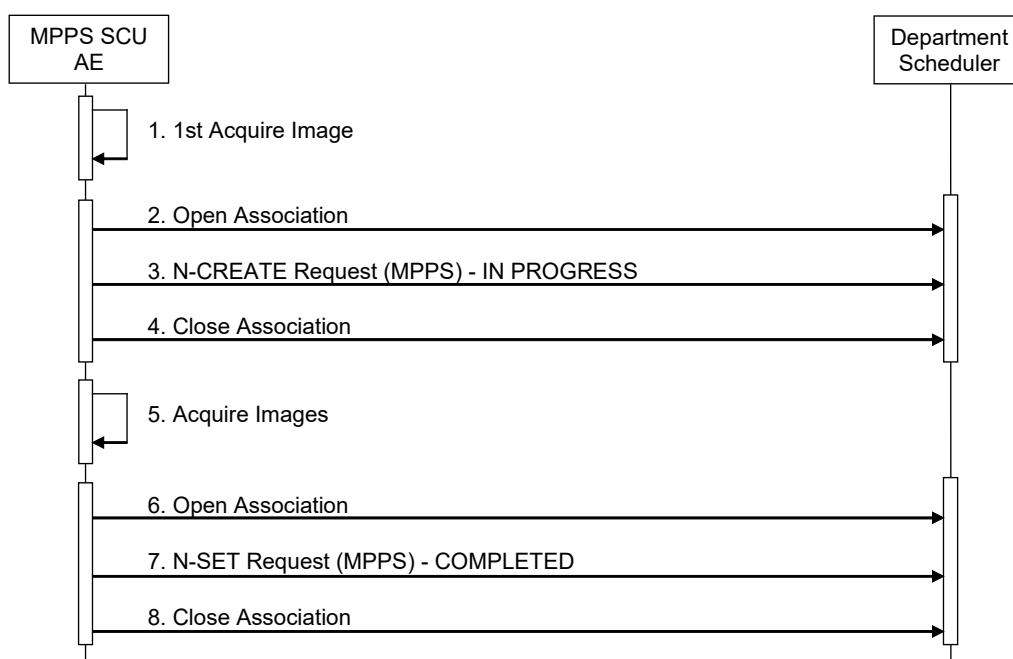

Figure 4.2-5
SEQUENCING OF ACTIVITY - ACQUIRE IMAGES

A possible sequence of interactions between the MPPS SCU AE and a Department Scheduler (e.g. a device such as a RIS or HIS which supports the MPPS SOP Class as an SCP) is illustrated in the Figure above:

1. 1st image is acquired and stored in the local database.
2. The MPPS SCU AE opens an association with the Department Scheduler
3. The MPPS SCU AE sends an N-CREATE request to the Department Scheduler to create an MPPS instance with status of "IN PROGRESS" and create all necessary attributes. The Department Scheduler acknowledges the MPPS creation with an N-CREATE response (status success).
4. The MPPS SCU AE closes the association with the Department Scheduler.
5. All images are acquired and stored in the local database.
6. The MPPS SCU AE opens an association with the Department Scheduler.

7. The MPPS SCU AE sends an N-SET request to the Department Scheduler to update the MPPS instance with status of "COMPLETED" and set all necessary attributes. The Department Scheduler acknowledges the MPPS update with an N-SET response (status success).
8. The MPPS SCU AE closes the association with the Department Scheduler.

4.2.4.3.1.2 Proposed Presentation Contexts

The MPPS SCU AE will propose Presentation Contexts as shown in the following table:

**Table 4.2-36
PROPOSED PRESENTATION CONTEXTS FOR REAL-WORLD ACTIVITY ACQUIRE IMAGES**

Presentation Context Table					
Abstract Syntax		Transfer Syntax		Role	Ext. Neg.
Name	UID	Name List	UID List		
Modality Performed Procedure Step	1.2.840.10008.3.1.2.3.3	Implicit VR Little Endian Explicit VR Little Endian	1.2.840.10008.1.2 1.2.840.10008.1.2.1	SCU	None

4.2.4.3.1.3 SOP Specific Conformance for MPPS SOP Class

The MPPS SCU AE provides standard conformance to the Modality Performed Procedure Step SOP Class as an SCU.

The behavior of the MPPS SCU AE when encountering status codes in an MPPS N-CREATE or N-SET response is summarized in the table below.

**Table 4.2-37
MPPS N-CREATE / N-SET RESPONSE STATUS HANDLING BEHAVIOR**

Service Status	Further Meaning	Status Code	Behavior
Success	Success	0000	The SCP has completed the operation successfully.
Failure	Processing Failure - Performed Procedure Step Object may no longer be updated	0110H	The Association is aborted and the MPPS is marked as failed. The status meaning is logged and reported to the user.
Warning	Attribute Value Out of Range	0116H	
*	*	Any other status codes.	

The behavior of the MPPS SCU AE during communication failure is summarized in the table below:

**Table 4.2-38
MPPS COMMUNICATION FAILURE BEHAVIOR**

Exception	Behavior
Timeout	The Association is aborted and the MPPS is marked as failed. The reason is logged and reported to the user.
Association aborted by the SCP or network layers	The MPPS is marked as failed. The reason is logged and reported to the user.

The table below provides a description of the MPPS N-CREATE and N-SET request identifiers sent by the MPPS SCU AE. Empty cells in the N-CREATE and N-SET columns indicate that the attribute is not sent. An "x" indicates that an appropriate value will be sent. A "Zero length" attribute will be sent with zero length.

**Table 4.2-39
MPPS N-CREATE / N-SET REQUEST IDENTIFIER**

Attribute Name	Tag	VR	N-CREATE	N-SET
Specific Character Set	(0008,0005)	CS	Created, if an extended or replacement character set is used.	Created, if an extended or replacement character set is used.
Modality	(0008,0060)	CS	x	
Procedure Code Sequence	(0008,1032)	SQ	Zero length	
Referenced Patient Sequence	(0008,1120)	SQ	Zero length	
> Referenced SOP Class UID	(0008,1150)	UI	x	
> Referenced SOP Instance UID	(0008,1155)	UI	x	
Patient's Name	(0010,0010)	PN	x	
Patient ID	(0010,0020)	LO	x	
Issuer of Patient ID	(0010,0021)	LO	x	
Patient's Birth Date	(0010,0030)	DA	x	
Patient's Sex	(0010,0040)	CS	x	
Study ID	(0020,0010)	SH	x	
Performed Station AE Title	(0040,0241)	AE	Local AE Title	
Performed Station Name	(0040,0242)	SH	Local Station Name	
Performed Location	(0040,0243)	SH	Zero length	
Performed Procedure Step Start Date	(0040,0244)	DA	Actual start date	
Performed Procedure Step Start Time	(0040,0245)	TM	Actual start time	
Performed Procedure Step End Date	(0040,0250)	DA	Zero length	Actual End date
Performed Procedure Step End Time	(0040,0251)	TM	Zero length	Actual End time
Performed Procedure Step Status	(0040,0252)	CS	IN PROGRESS	COMPLETED or DISCONTINUED
Performed Procedure Step ID	(0040,0253)	SH	x	
Performed Procedure Step Description	(0040,0254)	LO	From Modality Worklist	From Modality Worklist
Performed Procedure Type Description	(0040,0255)	LO	Zero length	Zero length
Performed Protocol Code Sequence	(0040,0260)	SQ	Zero length	Zero or more items
> Code Value	(0008,0100)	SH		x
> Coding Scheme Designator	(0008,0102)	SH		x
> Coding Scheme Version	(0008,0103)	SH		x
> Code Meaning	(0008,0104)	LO		x
Scheduled Step Attributes Sequence	(0040,0270)	SQ	One item	
> Accession Number	(0008,0050)	SH	x	
> Referenced Study Sequence	(0008,1110)	SQ	Zero length	
>> Referenced SOP Class UID	(0008,1150)	UI	x	
>> Referenced SOP Instance UID	(0008,1155)	UI	x	

Attribute Name	Tag	VR	N-CREATE	N-SET
> Study Instance UID	(0020,000D)	UI	x	
> Requested Procedure Description	(0032,1060)	LO	From Modality Worklist	
> Requested Procedure Code Sequence	(0032,1064)	SQ		
>> Code Value	(0008,0100)	SH		
>> Coding Scheme Designator	(0008,0102)	SH		
>> Coding Scheme Version	(0008,0103)	SH		
>> Code Meaning	(0008,0104)	LO		
> Scheduled Procedure Step Description	(0040,0007)	LO	From Modality Worklist	
> Scheduled Protocol Code Sequence	(0040,0008)	SQ	Zero or more items	
>> Code Value	(0008,0100)	SH	From Modality Worklist	
>> Coding Scheme Designator	(0008,0102)	SH	From Modality Worklist	
>> Coding Scheme Version	(0008,0103)	SH	From Modality Worklist	
>> Code Meaning	(0008,0104)	LO	From Modality Worklist	
> Scheduled Procedure Step ID	(0040,0009)	SH	From Modality Worklist	
> Requested Procedure ID	(0040,1001)	SH	From Modality Worklist	
Total Time of Fluoroscopy	(0040,0300)	US		See marginal Note
Total Number of Exposures	(0040,0301)	US		See marginal Note
Distance Source to Detector	(0018,1110)	DS		See marginal Note
Distance Source to Entrance	(0040,0306)	DS		See marginal Note
Image and Fluoroscopy Area Dose Product	(0018,115E)	DS		See marginal Note
Exposure Dose Sequence	(0040,030E)	SQ		See marginal Note
> Radiation Mode	(0018,115A)	CS		See marginal Note
> KVP	(0018,0060)	DS		See marginal Note
> X-Ray Tube Current in μ A	(0018,8151)	DS		See marginal Note
> Exposure Time	(0018,1150)	IS		See marginal Note
Performed Series Sequence	(0040,0340)	SQ	Zero length	One item
> Retrieve AE Title	(0008,0054)	AE		Zero length
> Series Description	(0008,103E)	LO		Zero length
> Performing Physician's Name	(0008,1050)	PN		x
> Operators' Name	(0008,1070)	PN		x
> Referenced Image Sequence	(0008,1140)	SQ		One or more items
>> Referenced SOP Class UID	(0008,1150)	UI		x
>> Referenced SOP Instance UID	(0008,1155)	UI		x
> Protocol Name	(0018,1030)	LO		x
> Series Instance UID	(0020,000E)	UI		x
> Referenced Non-Image Composite SOP Instance Sequence	(0040,0220)	SQ		Zero length

Note: Whether or not to output the value depends on the setting.

4.2.4.4 Association Acceptance Policy

The MPPS SCU AE does not accept Associations.

4.2.5 Q/R SCU AE Specification

4.2.5.1 SOP Classes

The Q/R SCU AE provides Standard Conformance to the following SOP Classes:

Table 4.2-40
SOP CLASSES FOR THE Q/R SCU AE

SOP Class Name	SOP Class UID	SCU	SCP
Study Root Q/R Information Model - FIND	1.2.840.10008.5.1.4.1.2.2.1	Yes	No
Study Root Q/R Information Model - MOVE	1.2.840.10008.5.1.4.1.2.2.2	Yes	No

4.2.5.2 Association Policies

4.2.5.2.1 General

The DICOM standard application context name for DICOM 3.0 is always proposed:

Table 4.2-41
DICOM APPLICATION CONTEXT FOR THE Q/R SCU AE

Application Context Name	1.2.840.10008.3.1.1.1
--------------------------	-----------------------

4.2.5.2.2 Number of Associations

The Q/R SCU AE initiates one Association at a time.

Table 4.2-42
NUMBER OF ASSOCIATIONS INITIATED FOR THE Q/R SCU AE

Maximum number of simultaneous Associations	1
---	---

4.2.5.2.3 Asynchronous Nature

The Q/R SCU AE does not support asynchronous communication (multiple outstanding transactions over a single Association).

Table 4.2-43
ASYNCHRONOUS NATURE FOR THE Q/R SCU AE

Maximum number of outstanding asynchronous transactions	1
---	---

4.2.5.2.4 Implementation Identifying Information

The implementation information for this Application Entity is:

Table 4.2-44
DICOM IMPLEMENTATION CLASS AND VERSION FOR THE Q/R SCU AE

Implementation Class UID	1.2.392.200036.9116.32.5
Implementation Version Name	UDR10A

4.2.5.3 Association Initiation Policy

4.2.5.3.1 Activity - Query and Retrieve Images

4.2.5.3.1.1 Description and Sequencing of Activities

The Q/R SCU AE is activated when the user selects or enters Patient ID. The user can select studies and series to be retrieved. The images will be received at the Storage SCP AE.

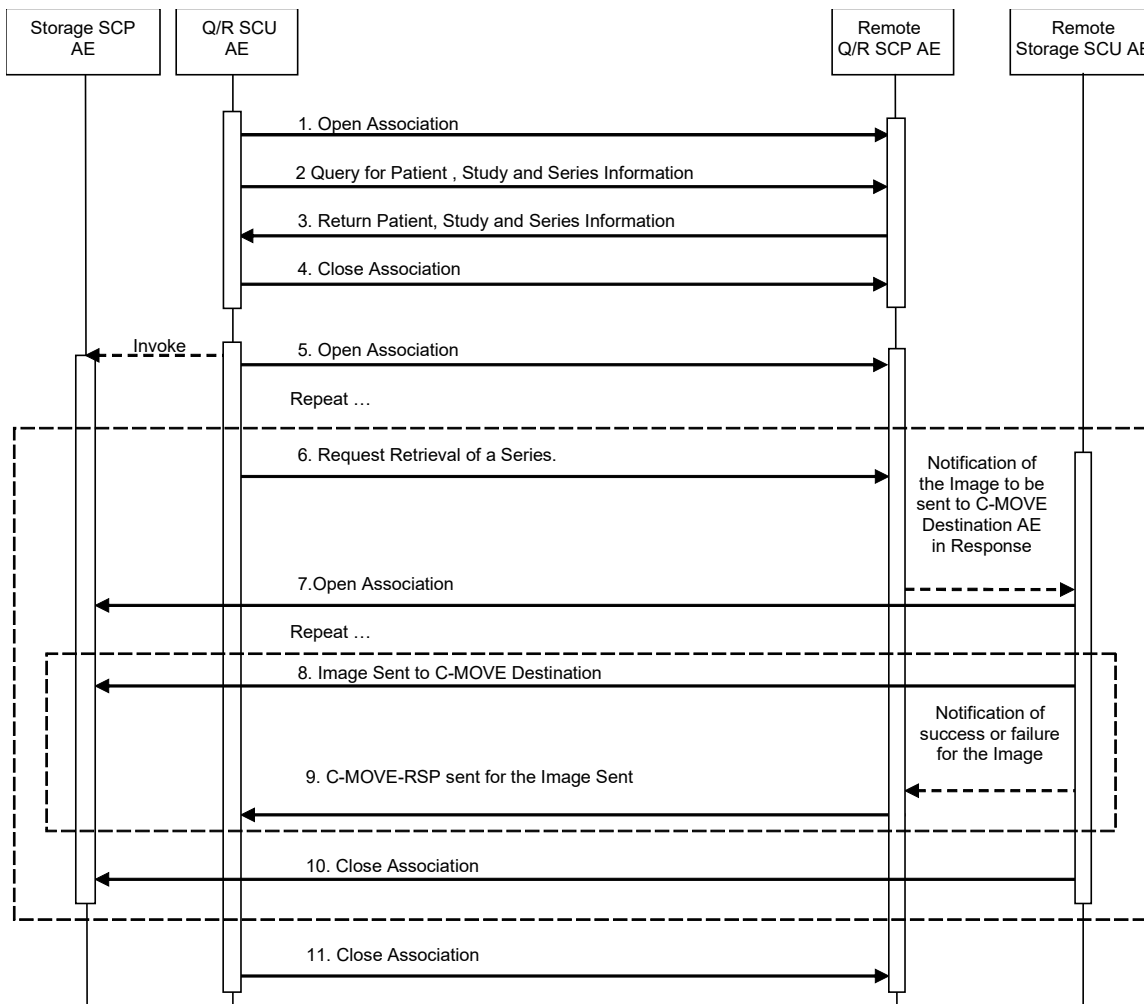

Figure 4.2-6
SEQUENCING OF ACTIVITY - QUERY AND RETRIEVE IMAGES

The following sequencing constraints illustrated in the Figure adobe:

1. The Q/R SCU AE opens an Association with the Q/R SCP AE.
2. The Q/R SCU AE sends a C-FIND-RQ Message
3. The Q/R SCP AE returns a C-FIND-RSP Message to the Q/R SCU AE with matching information. A C-FIND-RSP is sent for each entity matching the identifier specified in the C-FIND-RQ. A final C-FIND-RSP is sent indicating that the matching is complete.
4. The Q/R SCU AE closes the Association.
5. The Q/R SCU AE invokes Storage SCP AE and opens an Association with the Q/R SCP AE.
6. The Q/R SCU AE sends a C-MOVE-RQ Message. The Q/R SCP AE notifies the Storage SCU AE to send the Composite SOP Instances to the peer C-MOVE Destination AE as indicated in the C-MOVE-RQ.

7. The Storage SCU AE opens an Association with the C-MOVE Destination AE.
8. The Storage SCU AE sends images to the C-MOVE Destination AE. The Storage SCU AE indicates to the Q/R SCP AE whether the transfer succeeded or failed.
9. The Q/R SCP AE then returns a C-MOVE-RSP indicating this success or failure.
10. The Storage SCU AE closes the Association.
11. The Q/R SCU AE closes the Association.

All queries are initiated at the highest level of the information model (the STUDY level), and then for each response received, in order to completely elucidate the "tree" of instances available on the remote AE.

4.2.5.3.1.2 Proposed Presentation Contexts

The Q/R SCU AE will propose Presentation Contexts as shown in the following Table:

Table 4.2-45
PROPOSED PRESENTATION CONTEXTS FOR REAL-WORLD ACTIVITY
QUERY AND RETRIEVE IMAGES

Presentation Context Table					
Abstract Syntax		Transfer Syntax		Role	Ext. Neg.
Name	UID	Name List	UID List		
Study Root Q/R Information Model - FIND	1.2.840.10008.5.1.4.1.2.2.1	Implicit VR Little Endian	1.2.840.10008.1.2	SCU	None
Study Root Q/R Information Model - MOVE	1.2.840.10008.5.1.4.1.2.2.2	Implicit VR Little Endian	1.2.840.10008.1.2	SCU	None

4.2.5.3.1.3 SOP Specific Conformance for Q/R Find SOP Classes

The Q/R SCU AE provides standard conformance to the Query/Retrieve Find SOP Classes as an SCU.

The behavior of the Q/R SCU AE when encountering status codes in a Q/R C-FIND response is summarized in the Table below:

Table 4.2-46
Q/R C-FIND RESPONSE STATUS BEHAVIOR

Service Status	Further Meaning	Status Code	Behavior
Success	Matching is complete	0000	The Association is closed and the collected Study and Series information items are available for display or further processing.
Cancel	Matching terminated due to Cancel request	FE00	The Association is closed and the collected Study and Series information items are available for display or further processing.
Pending	Matches are continuing	FF00	The Study and Series information items contained in the Identifier is collected for later display or further processing.
Pending	Matches are continuing - Warning that one or more Optional Keys were not supported	FF01	The Study and Series information items contained in the Identifier is collected for later display or further processing.
*	*	Any other status codes.	The Association is aborted using A-ABORT and the Study and Series information is marked as failed. The status meaning is logged and reported to the user if an interactive query. Any additional error information in the Response will be logged.

The behavior of the Q/R SCU AE during communication failure is summarized in the Table below.

Table 4.2-47
Q/R C-FIND COMMUNICATION FAILURE BEHAVIOR

Exception	Behavior
Timeout	The Association is aborted using A-ABORT The reason is logged and reported to the user if an interactive query.
Association aborted by the SCP or network layers	The reason is logged and reported to the user if an interactive query.

The Tables below provides a description of the Q/R SCU AE C-FIND Request Identifier.

**Table 4.2-48
STUDY ROOT REQUEST IDENTIFIER FOR C-FIND**

Name	Tag	Types of Matching
STUDY Level		
Study Date	(0008,0020)	U
Study Time	(0008,0030)	U
Accession Number	(0008,0050)	U
Patient's Name	(0010,0010)	U , * (Note)
Patient ID	(0010,0020)	S,*
Study Instance UID	(0020,000D)	UNIQUE
Study ID	(0020,0010)	U
SERIES Level		
Modality	(0008,0060)	S
Protocol Name	(0018,1030)	U
Presentation Intent Type	(0008,0068)	U
Series Instance UID	(0020,000E)	UNIQUE
Series Number	(0020,0011)	U
Number of Series Related Instances	(0020,1209)	U

Types of Matching:

The types of Matching supported by the Q/R SCU AE. An "S" indicates the identifier attribute uses Single Value Matching, An "*" indicates wildcard matching, and a 'U' indicates Universal Matching. "UNIQUE" indicates that this is the Unique Key for that query level, in which case Universal Matching or Single Value Matching is used depending on the query level.

Note: It is possible not to require it as a matching key depending on the settings.

4.2.5.3.1.4 SOP Specific Conformance for Q/R Move SOP Classes

The Q/R SCU AE provides standard conformance to the Query/Retrieve Move SOP Classes as an SCU.

The behavior of the Q/R SCU AE when encountering status codes in a Q/R C-MOVE response is summarized in the Table below:

Table 4.2-49
Q/R C-MOVE RESPONSE STATUS BEHAVIOR

Service Status	Further Meaning	Status Code	Behavior
Success	Sub-operations complete - No Failures	0000	The Association is closed. If all SOP Instances in a move job have status success then the job is marked as complete.
Cancel	Sub-operations terminated due to Cancel Indication	FE00	The Association is closed. If all SOP Instances in a move job have status success then the job is marked as complete.
Pending	Sub-operations are continuing	FF00	Retrieval continues.
*	*	Any other status codes.	The Association is aborted using A-ABORT and the move job is marked as failed. The status meaning is logged and the job failure is reported to the user via the job control application.

The behavior of the Q/R SCU AE during communication failure is summarized in the Table below.

Table 4.2-50
Q/R C-MOVE COMMUNICATION FAILURE BEHAVIOR

Exception	Behavior
Timeout	The Association is aborted using A-ABORT. The reason is logged and reported to the user if an interactive query.
Association aborted by the SCP or network layers	The reason is logged and reported to the user if an interactive query.

The system requests Series Level Move only.

4.2.5.4 Association Acceptance Policy

The Q/R SCU AE does not accept Associations.

4.2.6 Storage SCP AE Specification

4.2.6.1 SOP Classes

The Storage SCP AE provides Standard Conformance to the following SOP Classes:

Table 4.2-51
SOP CLASSES FOR THE STORAGE SCP AE

SOP Class Name	SOP Class UID	SCU	SCP
X-Ray Radiofluoroscopic Image Storage	1.2.840.10008.5.1.4.1.1.12.2	No	Yes
X-Ray Angiographic Image Storage	1.2.840.10008.5.1.4.1.1.12.1	No	Yes
Computed Radiography Image Storage	1.2.840.10008.5.1.4.1.1.1	No	Yes
Digital X-Ray Image Storage - For Presentation	1.2.840.10008.5.1.4.1.1.1.1	No	Yes

4.2.6.2 Association Policies

4.2.6.2.1 General

The DICOM standard application context name for DICOM 3.0 is always proposed:

Table 4.2-52
DICOM APPLICATION CONTEXT FOR THE STORAGE SCP AE

Application Context Name	1.2.840.10008.3.1.1.1
--------------------------	-----------------------

4.2.6.2.2 Number of Associations

The Storage SCP AE initiates one Association at a time.

Table 4.2-53
NUMBER OF ASSOCIATIONS ACCEPTED FOR THE STORAGE SCP AE

Maximum number of simultaneous Associations	1
---	---

4.2.6.2.3 Asynchronous Nature

The Storage SCP AE does not support asynchronous communication (multiple outstanding transactions over a single Association).

Table 4.2-54
ASYNCHRONOUS NATURE FOR THE STORAGE SCP AE

Maximum number of outstanding asynchronous transactions	1
---	---

4.2.6.2.4 Implementation Identifying Information

The implementation information for the Storage SCP AE is:

Table 4.2-55
DICOM IMPLEMENTATION CLASS AND VERSION FOR THE STORAGE SCP AE

Implementation Class UID	1.2.392.200036.9116.32.5
Implementation Version Name	UDR10A

4.2.6.3 Association Initiation Policy

The Storage SCP AE does not initiate Associations.

4.2.6.4 Association Acceptance Policy

4.2.6.4.1 Description and Sequencing of Activities

The Storage SCP AE accepts Associations only if they have valid Presentation Contexts. If none of the requested Presentation Contexts are accepted then the Association Request itself is rejected. It can be configured to only accept Associations with certain hosts (using TCP/IP address) and/or Application Entity Titles. STORAGE SCP only operates during Retrieve by Q/R SCU AE. If an unrequested Study is sent, it cannot be displayed, even if it was successfully received, as it will not be listed.

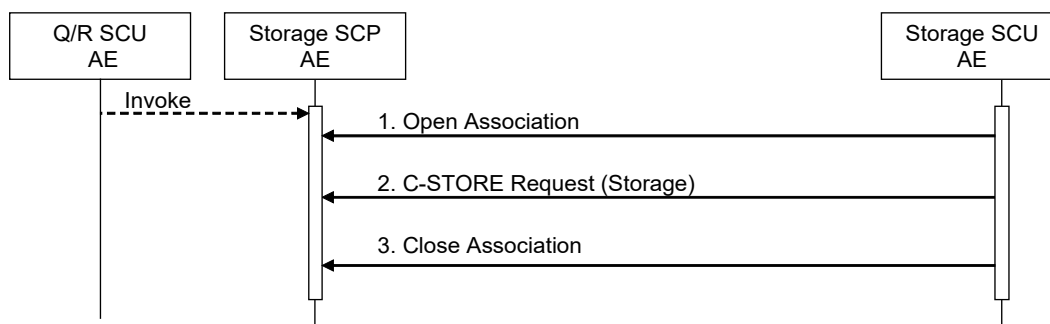

Figure 4.2-7
SEQUENCING OF ACTIVITY - STORE IMAGES TO THE LOCAL FILE SYSTEM

A possible sequence of interactions between the Storage SCP AE and a Storage SCU AE is illustrated in the Figure above:

1. The Storage SCU AE opens an Association with the Storage SCP AE.
2. The Storage SCU AE sends images to the Storage SCP AE using a Storage request (C-STORE) and the Storage SCP AE replies with a C-STORE response (status success).
3. The Storage SCU AE closes the Association with the Storage SCP AE.

The Storage SCP AE may reject Association attempts as shown in the Table below. The Result, Source and Reason/Diag columns represent the values returned in the corresponding fields of an ASSOCIATE-RJ PDU (see PS 3.8, Section 9.3.4).

Table 4.2-56
ASSOCIATION REJECTION REASONS

Result	Source	Reason/Diag	Explanation
2 - rejected-transient	DICOM UL service-provider (Presentation related function)	2 - local-limit-exceeded	The (configurable) maximum number of simultaneous Associations has been reached. An Association request with the same parameters may succeed at a later time.
2 - rejected-transient	DICOM UL service-provider (ACSE related function)	1 - no-reason-given	The Association request could not be parsed. An Association request with the same format may succeed at a later time.
1 - rejected-permanent	DICOM UL service-user	2 - application-context-name-not-supported	The Association request contained an unsupported Application Context Name. An association request with the same parameters will not succeed at a later time.

1 - rejected-permanent	DICOM UL service-user	7 - called-AE-title-not-recognized	The Association request contained an unrecognized Called AE Title. An Association request with the same parameters will not succeed at a later time unless configuration changes are made. This rejection reason normally occurs when the Association initiator is incorrectly configured and attempts to address the Association acceptor using the wrong AE Title.
1 - rejected-permanent	DICOM UL service-user	3 - calling-AE-title-not-recognized	The Association request contained an unrecognized Calling AE Title. An Association request with the same parameters will not succeed at a later time unless configuration changes are made. This rejection reason normally occurs when the Association acceptor has not been configured to recognize the AE Title of the Association initiator.
1 - rejected-permanent	DICOM UL service-provider (ACSE related function)	1 - no-reason-given	The Association request could not be parsed. An Association request with the same format will not succeed at a later time.

4.2.6.4.1.1 Accepted Presentation Contexts

The Storage SCP AE will accept Presentation Contexts as shown in the Table below.

Table 4.2-57

ACCEPTED PRESENTATION CONTEXTS BY THE STORAGE SCP AE

Presentation Context Table					
Abstract Syntax		Transfer Syntax		Role	Ext. Neg.
Name	UID	Name	UID		
X-Ray Radiofluoroscopic Image Storage	1.2.840.10008.5.1.4.1.1.12.2	Implicit VR Little Endian	1.2.840.10008.1.2	SCP	None
		Explicit VR Little Endian	1.2.840.10008.1.2.1		
X-Ray Angiographic Image Storage	1.2.840.10008.5.1.4.1.1.12.1	Implicit VR Little Endian	1.2.840.10008.1.2	SCP	None
		Explicit VR Little Endian	1.2.840.10008.1.2.1		
Computed Radiography Image Storage	1.2.840.10008.5.1.4.1.1.1	Implicit VR Little Endian	1.2.840.10008.1.2	SCP	None
		Explicit VR Little Endian	1.2.840.10008.1.2.1		
Digital X-Ray Image Storage - For Presentation	1.2.840.10008.5.1.4.1.1.1.1	Implicit VR Little Endian	1.2.840.10008.1.2	SCP	None
		Explicit VR Little Endian	1.2.840.10008.1.2.1		

4.2.6.4.2 SOP Specific Conformance for Storage SOP Classes

The Storage SCP AE provides standard conformance to the Storage SOP Class as an SCP.

The associated Activity with the Storage service is the storage of medical image data received over the network on a designated hard disk. The Storage SCP AE will return a failure status if it is unable to store the images on to the hard disk.

**Table 4.2-58
STORAGE SCP AE C-STORE RESPONSE STATUS RETURN REASONS**

Service Status	Further Meaning	Status Code	Reason
Success	Success	0000	The Composite SOP Instance was successfully received, verified, and stored in the system database.
Refused	Out of Resources	A700	Indicates that there were not enough local resources.
Error	Data Set does not match SOP Class	A900	Indicates that the Data Set does not encode a valid instance of the SOP Class specified.
	Cannot understand	C000	Indicates that the Storage SCP AE cannot parse the Data Set into Elements.

4.2.7 Print SCU AE Specification

4.2.7.1 SOP Classes

The Print SCU AE provides Standard Conformance to the following Meta SOP Classes:

Table 4.2-59
META SOP CLASSES FOR THE PRINT SCU AE

SOP Class Name	SOP Class UID	SCU	SCP
Basic Grayscale Print Management Meta	1.2.840.10008.5.1.1.9	Yes	No

The above Meta SOP Classes are defined by the following set of supported SOP Classes:

Table 4.2-60
SOP CLASSES FOR THE PRINT SCU AE

SOP Class Name	SOP Class UID	SCU	SCP
Basic Film Session SOP Class	1.2.840.10008.5.1.1.1	Yes	No
Basic Film Box SOP Class	1.2.840.10008.5.1.1.2	Yes	No
Basic Grayscale Image Box SOP Class	1.2.840.10008.5.1.1.4	Yes	No
Printer SOP Class	1.2.840.10008.5.1.1.16	Yes	No

4.2.7.2 Association Policies

4.2.7.2.1 General

The DICOM standard application context name for DICOM 3.0 is always proposed:

Table 4.2-61
DICOM APPLICATION CONTEXT FOR THE PRINT SCU AE

Application Context Name	1.2.840.10008.3.1.1.1
--------------------------	-----------------------

4.2.7.2.2 Number of Associations

The Print SCU AE can initiate one Association at a time for each destination to which a transfer request is being processed in the active job queue list. Only one job will be active at a time, the other remains pending until the active job is completed or failed.

Table 4.2-62
NUMBER OF ASSOCIATIONS INITIATED FOR THE PRINT SCU AE

Maximum number of simultaneous Associations	1
---	---

4.2.7.2.3 Asynchronous Nature

The Print SCU AE does not support asynchronous communication (multiple outstanding transactions over a single Association).

Table 4.2-63
ASYNCHRONOUS NATURE FOR THE PRINT SCU AE

Maximum number of outstanding asynchronous transactions	1
---	---

4.2.7.2.4 Implementation Identifying Information

The implementation information for the Print SCU AE is:

Table 4.2-64
DICOM IMPLEMENTATION CLASS AND VERSION FOR THE PRINT SCU AE

Implementation Class UID	1.2.392.200036.9116.32.5
Implementation Version Name	UDR10A

4.2.7.3 Association Initiation Policy

4.2.7.3.1 Activity - Send Images & Print Management Information

4.2.7.3.1.1 Description and Sequencing of Activities

A user composes images onto film sheets and requests them to be sent to a specific hardcopy device. The user can select the desired film size.

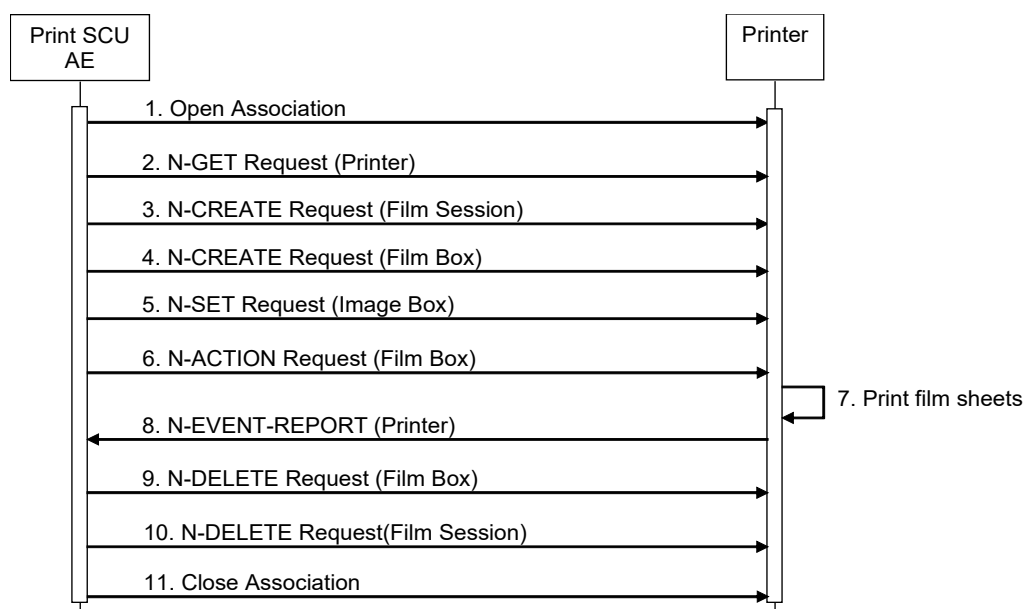

Figure 4.2-8
SEQUENCING OF ACTIVITY - SEND IMAGES & PRINT MANAGEMENT INFORMATION

A typical sequence of DIMSE messages sent over an association between the Print SCU AE and a Printer is illustrated in the Figure above:

1. The Print SCU AE opens an Association with the Printer.
2. N-GET on the Printer SOP Class is used to obtain current printer status information. If the Printer reports a status of FAILURE, the Print SCU closes the Association and waits and retries from the beginning.
3. N-CREATE on the Film Session SOP Class creates a Film Session.
4. N-CREATE on the Film Box SOP Class creates a Film Box linked to the Film Session.
5. N-SET on the Image Box SOP Class transfers the contents of the film sheet to the printer.
6. N-ACTION on the Film Box SOP Class instructs the Printer to print the Film Box.
7. The printer prints the requested number of film sheets.
8. The Printer asynchronously reports its status via N-EVENT-REPORT notification (Printer SOP Class). The printer can send this message at any time. The Print SCU AE does not require the N-EVENT-REPORT to be sent. The Print SCU AE is capable of receiving an N-EVENT-REPORT notification at any time during an association. If the Printer reports a status of FAILURE, the print-job is switched to a failed state and the user informed.
9. N-DELETE on the Film Session SOP Class deletes the complete Film Session SOP Instance hierarchy.
10. N-DELETE on the Film Box SOP Class deletes the complete Film Box SOP Instance hierarchy.
11. The Print SCU AE closes the Association with the Printer.

4.2.7.3.1.2 Proposed Presentation Contexts

The Print SCU AE is capable of proposing the Presentation Contexts shown in the table below:

Table 4.2-65
PROPOSED PRESENTATION CONTEXTS FOR ACTIVITY
SEND IMAGES & PRINT MANAGEMENT INFORMATION

Presentation Context Table					
Abstract Syntax		Transfer Syntax		Role	Ext. Neg.
Name	UID	Name List	UID List		
Basic Grayscale Print Management Meta	1.2.840.10008.5.1.1.9	Implicit VR Little Endian Explicit VR Little Endian	1.2.840.10008.1.2 1.2.840.10008.1.2.1	SCU	None

4.2.7.3.1.3 Common SOP Specific Conformance for all Print SOP Classes

The general behavior of the Print SCU AE during communication failure is summarized in the table below. This behavior is common for all SOP Classes supported by the Print SCU AE.

Table 4.2-66
PRINT COMMUNICATION FAILURE BEHAVIOR

Exception	Behavior
Timeout	The Association is aborted and the print-job is marked as failed. The reason is logged and the job failure is reported to the user via the job control application.
Association aborted by the SCP or network layers	The print-job is marked as failed. The reason is logged and the job failure is reported to the user via the job control application.

4.2.7.3.1.4 SOP Specific Conformance for Printer SOP Class

The Print SCU AE supports the following DIMSE operations and notifications for the Printer SOP Class:

- N-GET
- N-EVENT-REPORT

Details of the supported attributes and status handling behavior are described in the following subsections.

4.2.7.3.1.4.1 Printer SOP Class Operations (N-GET)

The Print SCU AE uses the Printer SOP Class N-GET operation to obtain information about the current printer status. The attributes obtained via N-GET are listed in the table below:

Table 4.2-67
PRINTER SOP CLASS N-GET REQUEST ATTRIBUTES

Attribute Name	Tag	VR	Value	Presence of Value	Source
Printer Status	(2110,0010)	CS	Provided by Printer	ALWAYS	Printer
Printer Status Info	(2110,0020)	CS	Provided by Printer	ALWAYS	Printer

The Printer Status information is evaluated as follows:

1. If Printer Status (2110,0010) is NORMAL, the print-job continues to be printed.
2. If Printer Status (2110,0010) is FAILURE or WARNING, the print-job is marked as failed. The contents of Printer Status Info (2110,0020) is logged and reported to the user via the job control application.
3. If Printer status (2110,0010) is WARNING, the print-job continues to be printed. The contents of Printer Status Info (2110,0020) is logged and reported to the user via the job control application.
4. If Printer status (2110,0010) is empty, the print-job continues to be printed. The contents of Printer Status Info (2110,0020) is logged as NOT READY and reported to the user via the job control application.

The behavior of The Print SCU AE when encountering status codes in an N-GET response is summarized in the table below:

Table 4.2-68
PRINTER SOP CLASS N-GET RESPONSE STATUS HANDLING BEHAVIOR

Service Status	Further Meaning	Status Code	Behavior
Success	Success	0000	The request to get printer status information was success.
*	*	Any other status code.	The Association is aborted and the status meaning is logged and reported to the user.

4.2.7.3.1.4.2 Printer SOP Class Operations (N-EVENT-REPORT)

The Print SCU AE capable of receiving an N-EVENT-REPORT request at any time during an association.

The behavior of The Print SCU AE when receiving Event Types within the N-EVENT-REPORT is summarized in the Table below.:

Table 4.2-69
PRINTER SOP CLASS N-EVENT-REPORT BEHAVIOUR

Event Type Name	Event Type ID	Behavior
Normal	1	The Print-job continues to be printed.
Warning	2	The print-job continues to be printed. The contents of Printer Status info(2110,0020) is logged and reported to the user via the job-control application.
Failure	3	The print-job is marked as failed. The contents of Printer Status info(2110,0020)is logged and reported to the user via the job-control application.
*	*	An invalid Event Type ID will cause a status code of 0113H to be returned in a N-EVENT-REPORT response.

The reasons for returning specific status codes in a N-EVENT-REPORT response are summarized in the Table below:

Table 4.2-70
PRINTER SOP CLASS N-EVENT-REPORT RESPONSE STATUS REASONS

Service Status	Further Meaning	Status Code	Behavior
Success	Success	0000	The notification event has been successfully received
Failure	No Such Event Type	0113H	An Invalid Event Type ID was supplied in the N-EVENT-REPORT request

Failure	Processing Failure	0110H	An internal error occurred during processing of the N-EVENT-REPORT. A short description of the error will be returned inf Error Comment(0000,0902)
---------	--------------------	-------	--

4.2.7.3.1.5 SOP Specific Conformance for the Film Session SOP Class

The Print SCU AE supports the following DIMSE operations for the Film Session SOP Class:

- N-CREATE
- N-DELETE

Details of the supported attributes and status handling behavior are described in the following subsections.

4.2.7.3.1.5.1 Film Session SOP Class Operations (N-CREATE)

The attributes supplied in an N-CREATE Request are listed in the table below:

**Table 4.2-71
FILM SESSION SOP CLASS N-CREATE REQUEST ATTRIBUTES**

Attribute Name	Tag	VR	Value	Presence of Value	Source
Number of Copies	(2000,0010)	IS	1	ALWAYS	AUTO
Print Priority	(2000,0020)	CS	HIGH	ALWAYS	AUTO
Medium Type	(2000,0030)	CS	BLUE FILM or CLEAR FILM or PAPER	ALWAYS	CONFIG
Film Destination	(2000,0040)	CS	MAGAZINE or PROCESSOR	ALWAYS	CONFIG

The behavior of The Print SCU AE when encountering status codes in an N-CREATE response is summarized in the table below:

**Table 4.2-72
FILM SESSION SOP CLASS N-CREATE RESPONSE STATUS HANDLING BEHAVIOR**

Service Status	Further Meaning	Status Code	Behavior
Success	Success	0000	The SCP has completed the operation successfully.
Warning	Attribute Value Out of Range	0116H	The N-CREATE operation is considered successful.
Warning	Attribute List Error	0107H	
*	*	Any other status code.	The Association is aborted and the print-job is marked as failed. The status meaning is logged and reported to the user.

4.2.7.3.1.5.2 Film Session SOP Class Operations (N-DELETE)

The behavior of The Print SCU AE when encountering status codes in an N-DELETE response is summarized in the table below:

**Table 4.2-73
PRINTER SOP CLASS N-DELETE RESPONSE STATUS HANDLING BEHAVIOR**

Service Status	Further Meaning	Status Code	Behavior
Success	Success	0000	The SCP has completed the operation successfully.
*	*	Any other status code.	The Association is aborted and the print-job is marked as failed. The status meaning is logged and reported to the user.

4.2.7.3.1.6 SOP Specific Conformance for the Film Box SOP Class

The Print SCU AE supports the following DIMSE operations for the Film Box SOP Class:

- N-CREATE

— N-ACTION

Details of the supported attributes and status handling behavior are described in the following subsections.

4.2.7.3.1.6.1 Film Box SOP Class Operations (N-CREATE)

The attributes supplied in an N-CREATE Request are listed in the table below:

**Table 4.2-74
FILM BOX SOP CLASS N-CREATE REQUEST ATTRIBUTES**

Attribute Name	Tag	VR	Value	Presence of Value	Source
Image Display Format	(2010,0010)	CS	STANDARD\2,2 etc.	ALWAYS	USER
Film Orientation	(2010,0040)	CS	PORTRAIT or LANDSCAPE	ALWAYS	USER
Film Size ID	(2010,0050)	CS	14INX17IN, 14INX14IN, 10INX14IN,8INX10IN	ALWAYS	USER
Magnification Type	(2010,0060)	CS	REPLICATE, BILINEAR, CUBIC or NONE	ALWAYS	CONFIG
Smoothing Type	(2010,0080)	CS	SHARP or SMOOTH	ALWAYS	CONFIG
Border Density	(2010,0100)	CS	BLACK or WHITE	ALWAYS	CONFIG
Empty Image Density	(2010,0110)	CS	BLACK	ALWAYS	CONFIG
Min Density	(2010,0120)	US	e.g. 300	ALWAYS	CONFIG
Max Density	(2010,0130)	US	e.g. 0	ALWAYS	CONFIG
Trim	(2010,0140)	CS	NO	ALWAYS	CONFIG
Referenced Film Session Sequence	(2010,0500)	SQ		ALWAYS	AUTO
>Referenced SOP Class UID	(0008,1150)	UI	1.2.840.10008.5.1.1.1	ALWAYS	AUTO
>Referenced SOP Instance UID	(0008,1155)	UI	From created Film Session SOP Instance	ALWAYS	AUTO

The behavior of the Print SCU AE when encountering status codes in an N-CREATE response is summarized in the table below:

**Table 4.2-75
FILM BOX SOP CLASS N-CREATE RESPONSE STATUS HANDLING BEHAVIOR**

Service Status	Further Meaning	Status Code	Behavior
Success	Success	0000	The SCP has completed the operation successfully.
Warning	Attribute Value Out of Range	0116H	The N-CREATE operation is considered successful.
Warning	Attribute List Error	0107H	
Warning	Requested Min Density or Max Density outside of printer's operating range	B605H	
*	*	Any other status code.	The Association is aborted and the print-job is marked as failed. The status meaning is logged and reported to the user.

4.2.7.3.1.6.2 Film Box SOP Class Operations (N-ACTION)

An N-ACTION Request is issued to instruct the Print SCP to print the contents of the Film Box. The Action Reply argument in an N-ACTION response is not evaluated.

The behavior of The Print SCU AE when encountering status codes in an N-ACTION response is summarized in the table below:

**Table 4.2-76
FILM BOX SOP CLASS N-ACTION RESPONSE STATUS HANDLING BEHAVIOR**

Service Status	Further Meaning	Status Code	Behavior
Success	Success	0000	The SCP has completed the operation successfully. The film has been accepted for printing.
Warning	Image size is larger than Image Box size. The image has been demagnified.	B604H	The N-ACTION operation is considered successful.
Warning	Image size is larger than Image Box size. The image has been cropped to fit.	B609H	
Warning	Image size or Combined Print Image Size is larger than Image Box size. The image or combined Print Image has been decimated to fit.	B60AH	
Failure	Unable to create Print Job SOP Instance; print queue is full.	C602H	The Association is aborted and the print-job is marked as failed. The status meaning is logged and reported to the user.
Failure	Image size is larger than Image Box size.	C603H	
Failure	Combined Print Image Size is larger than Image Box size.	C613H	
*	*	Any other status code.	

4.2.7.3.1.7 SOP Specific Conformance for the Grayscale Image Box SOP Class

The Print SCU AE supports the following DIMSE operations for the Grayscale Image Box SOP Class:

— N-SET

Details of the supported attributes and status handling behavior are described in the following subsections.

4.2.7.3.1.7.1 Grayscale Image Box SOP Class Operations (N-SET)

The attributes supplied in an N-SET Request are listed in the table below:

**Table 4.2-77
GRAYSCALE IMAGE BOX SOP CLASS N-SET REQUEST ATTRIBUTES**

Attribute Name	Tag	VR	Value	Presence of Value	Source
Image Position	(2020,0010)	US	1	ALWAYS	AUTO
Basic Grayscale Image Sequence	(2020,0110)	SQ		ALWAYS	AUTO
>Samples Per Pixel	(0028,0002)	US	1	ALWAYS	AUTO
>Photometric Interpretation	(0028,0004)	CS	MONOCHROME2	ALWAYS	AUTO
>Rows	(0028,0010)	US	2816 ,3092 etc.	ALWAYS	AUTO
>Columns	(0028,0011)	US	2016 , 2688,4032 etc.	ALWAYS	AUTO
>Pixel Aspect Ratio	(0028,0034)	IS		ALWAYS	AUTO
>Bits Allocated	(0028,0100)	US	8	ALWAYS	AUTO
>Bits Stored	(0028,0101)	US	8	ALWAYS	AUTO
>High Bit	(0028,0102)	US	7	ALWAYS	AUTO
>Pixel Representation	(0028,0103)	US	0	ALWAYS	AUTO
>Pixel Data	(7FE0,0010)	OW		ALWAYS	AUTO

The behavior of the Print SCU AE when encountering status codes in an N-SET response is summarized in the table below:

**Table 4.2-78
GRAYSCALE IMAGE BOX SOP CLASS N-SET RESPONSE STATUS HANDLING BEHAVIOR**

Service Status	Further Meaning	Status Code	Behavior
Success	Success	0000	The SCP has completed the operation successfully. Image successfully stored in Image Box.
Warning	Attribute Value Out of Range	0116H	The N-SET operation is considered successful.
Warning	Attribute List Error	0107H	
Warning	Image size is larger than Image Box size. The image has been demagnified.	B604H	
Warning	Requested Min Density or Max Density outside of printer's operating range.	B605H	
Warning	Image size is larger than Image Box size. The image has been cropped to fit.	B609H	
Warning	Image size or Combined Print Image Size is larger than Image Box size. The image or combined Print Image has been decimated to fit.	B60AH	
Failure	Image size is larger than Image Box size.	C603H	The Association is aborted and the print-job is marked as failed. The status meaning is logged and reported to the user.
Failure	Insufficient memory in printer to store the image.	C605H	
Failure	Combined Print Image Size is larger than Image Box size.	C613H	
*	*	Any other status code.	

4.2.7.4 Association Acceptance Policy

The Print SCU AE does not accept Associations.

4.2.8 Verification SCU AE Specification

4.2.8.1 SOP Classes

The Verification SCU AE provides Standard Conformance to the following SOP Classes:

Table 4.2-79
SOP CLASSES FOR THE VERIFICATION SCU AE

SOP Class Name	SOP Class UID	SCU	SCP
Verification	1.2.840.10008.1.1	Yes	No

4.2.8.2 Association Policies

4.2.8.2.1 General

The DICOM standard application context name for DICOM 3.0 is always proposed:

Table 4.2-80
DICOM APPLICATION CONTEXT FOR THE STORAGE SCU AE

Application Context Name	1.2.840.10008.3.1.1.1
--------------------------	-----------------------

4.2.8.2.2 Number of Associations

The Verification SCU AE can initiate one Association at a time.

Table 4.2-81
NUMBER OF ASSOCIATIONS INITIATED FOR THE VERIFICATION SCU AE

Maximum number of simultaneous Associations	1
---	---

4.2.8.2.3 Asynchronous Nature

The Verification SCU AE does not support asynchronous communication (multiple outstanding transactions over a single Association).

Table 4.2-82
ASYNCHRONOUS NATURE FOR THE VERIFICATION SCU AE

Maximum number of outstanding asynchronous transactions	1
---	---

4.2.8.2.4 Implementation Identifying Information

The implementation information for the Verification SCU AE is:

Table 4.2-83
DICOM IMPLEMENTATION CLASS AND VERSION FOR THE VERIFICATION SCU AE

Implementation Class UID	1.2.392.200036.9116.32.5
Implementation Version Name	UDR10A

4.2.8.3 Association Initiation Policy

4.2.8.3.1 Activity - Verify Connectivity

4.2.8.3.1.1 Description and Sequencing of Activities

A user request to verify the connectivity. Upon this request, the Verification SCU AE attempts to initiate a new Association in order to issue a Verification request (C-ECHO).

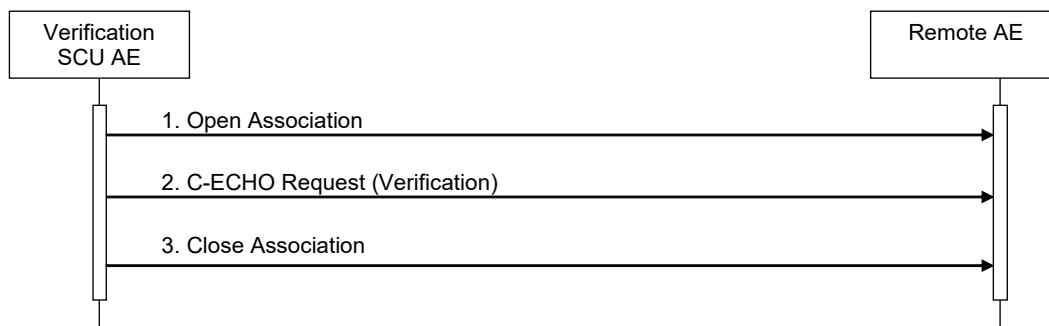

Figure 4.2-9
SEQUENCING OF ACTIVITY - VERIFY CONNECTIVITY (C-ECHO)

A possible sequence of interactions between the Verification SCU AE and a remote AE is illustrated in the Figure above:

1. The Verification SCU AE opens an Association with a remote AE.
2. The Verification SCU AE issues a Verification request (C-ECHO) and a remote AE replies with a C-ECHO response (status success).
3. The Verification SCU AE closes the Association with a remote AE.

The local AE also verifies the connectivity to Image Server(s) and Modality Worklist Server periodically (default; every 2 minutes; configurable using the Service Tool by the Field Service Engineer). In this case the Verification SCU AE also attempts to initiate a new Association periodically (negotiation) but does not issue a C-ECHO.

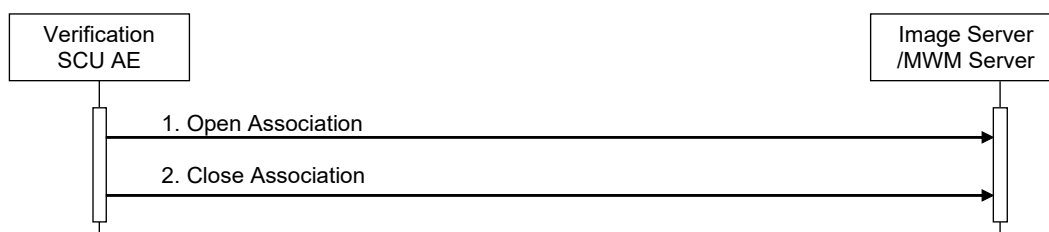

Figure 4.2-10
SEQUENCING OF ACTIVITY - VERIFY CONNECTIVITY (NEGOTIATION)

A possible sequence of interactions between the Verification SCU AE and a remote AE is illustrated in the Figure above:

1. The Verification SCU AE opens an Association with a remote AE.
2. The Verification SCU AE closes the Association with a remote AE.

4.2.8.3.1.2 Proposed Presentation Contexts

The Verification SCU AE is capable of proposing the Presentation Contexts shown in the following table:

**Table 4.2-84
PROPOSED PRESENTATION CONTEXTS FOR ACTIVITY VERIFY CONNECTIVITY**

Presentation Context Table					
Abstract Syntax		Transfer Syntax		Role	Ext. Neg.
Name	UID	Name List	UID List		
Verification	1.2.840.10008.1.1	Implicit VR Little Endian	1.2.840.10008.1.2	SCU	None
		Explicit VR Little Endian	1.2.840.10008.1.2.1		

4.2.8.3.1.3 SOP Specific Conformance for Verification SOP Classes

The Verification SCU AE provides standard conformance to the Verification Service Class as an SCU.

The behavior of Verification SCU AE when encountering status codes in a C-ECHO response is summarized in the table below:

**Table 4.2-85
VERIFICATION C-ECHO RESPONSE STATUS HANDLING BEHAVIOR**

Service Status	Further Meaning	Status Code	Behavior
Success	Success	0000	The Verification SCU AE judges the remote AE is present and active on the network.

The behavior of Verification SCU AE during communication failure is summarized in the table below:

**Table 4.2-86
VERIFICATION COMMUNICATION FAILURE BEHAVIOR**

Exception	Behavior
Timeout	The Association is aborted and the remote AE is marked as failed. The reason is logged and the remote AE failure is reported to the user.
Association aborted by the SCP or network layers	The Association is aborted and the remote AE is marked as failed. The reason is logged and the remote AE failure is reported to the user.

4.2.9 Verification SCP AE Specification

4.2.9.1 SOP Classes

The Verification SCP AE provides Standard Conformance to the following SOP Classes:

Table 4.2-87
SOP CLASSES FOR THE VERIFICATION SCP AE

SOP Class Name	SOP Class UID	SCU	SCP
Verification	1.2.840.10008.1.1	No	Yes

4.2.9.2 Association Policies

4.2.9.2.1 General

The DICOM standard application context name for DICOM 3.0 is always proposed:

Table 4.2-88
DICOM APPLICATION CONTEXT FOR THE STORAGE SCP AE

Application Context Name	1.2.840.10008.3.1.1.1
--------------------------	-----------------------

4.2.9.2.2 Number of Associations

The Verification SCP AE can initiate one Association at a time.

Table 4.2-89
NUMBER OF ASSOCIATIONS INITIATED FOR THE VERIFICATION SCP AE

Maximum number of simultaneous Associations	1
---	---

4.2.9.2.3 Asynchronous Nature

The Verification SCP AE does not support asynchronous communication (multiple outstanding transactions over a single Association).

Table 4.2-90
ASYNCHRONOUS NATURE FOR THE VERIFICATION SCP AE

Maximum number of outstanding asynchronous transactions	1
---	---

4.2.9.2.4 Implementation Identifying Information

The implementation information for the Verification SCP AE is:

Table 4.2-91
DICOM IMPLEMENTATION CLASS AND VERSION FOR THE VERIFICATION SCP AE

Implementation Class UID	1.2.392.200036.9116.32.5
Implementation Version Name	UDR10A

4.2.9.3 Association Initiation Policy

4.2.9.3.1 Activity - Verify Connectivity

4.2.9.3.1.1 Description and Sequencing of Activities

When the Verification SCP AE accepts an association, it will respond to a verification request (C-ECHO).

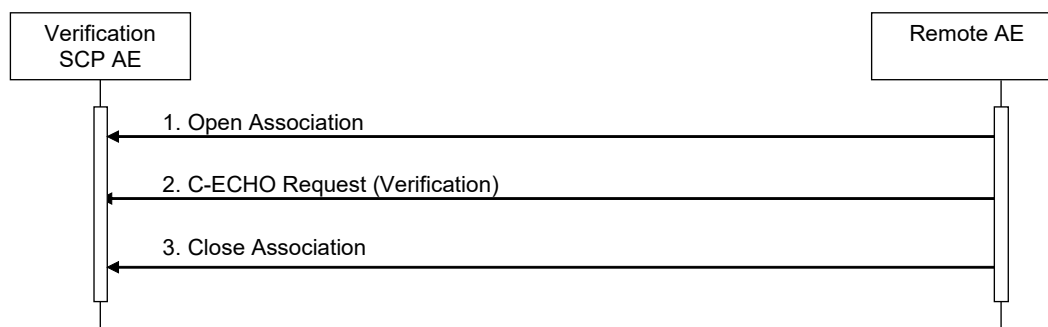

Figure 4.2-11
SEQUENCING OF ACTIVITY - VERIFY CONNECTIVITY

A possible sequence of interactions between the Verification SCP AE and a remote AE is illustrated in the Figure above:

1. The remote AE opens an Association with Verification SCP AE.
2. The remote AE issues a Verification request (C-ECHO) and Verification SCP AE replies with a C-ECHO response (status success).
3. The remote AE closes the Association with Verification SCP AE.

The Verification SCP AE may reject association attempts as shown in the Table below. The Result, Source and Reason/Diag columns represent the values returned in the appropriate fields of an ASSOCIATE-RJ PDU. The contents of the Source column is abbreviated to save space and the meaning of the abbreviations are:

Table 4.2-92
ASSOCIATION REJECTION REASONS

Result	Source	Reason/Diag	Explanation
1 - rejected-permanent	DICOM UL service-user	3 - calling-AE-title- not-recognized	The association request contained an unrecognized calling AE Title. An association request with the same parameters will not succeed at a later time unless configuration changes are made. This rejection reason normally occurs when the association acceptor has not been configured to recognize the AE Title of the association initiator.
1 - rejected-permanent	DICOM UL service-provider (ASCE related function)	1 - no-reason-given	The association request could not be parsed. An association request with the same format will not succeed at a later time.

4.2.9.3.1.2 Proposed Presentation Contexts

The Verification SCP AE is capable of proposing the Presentation Contexts shown in the following table:

**Table 4.2-93
PROPOSED PRESENTATION CONTEXTS FOR ACTIVITY VERIFY CONNECTIVITY**

Presentation Context Table					
Abstract Syntax		Transfer Syntax		Role	Ext. Neg.
Name	UID	Name List	UID List		
Verification	1.2.840.10008.1.1	Implicit VR Little Endian	1.2.840.10008.1.2	SCP	None
		Explicit VR Little Endian	1.2.840.10008.1.2.1		

4.2.9.3.1.3 SOP Specific Conformance for Verification SOP Classes

The Verification SCP AE provides standard conformance to the Verification Service Class as an SCP.

4.3 NETWORK INTERFACES

4.3.1 Physical Network Interface

This Product supports a single network interface. One of the following physical network interfaces will be available depending on installed hardware options:

Table 4.3-1
SUPPORTED PHYSICAL NETWORK INTERFACES

Ethernet 1000BASE-T
Ethernet 100BASE-TX
Ethernet 10BASE-T

4.3.2 Additional Protocols

None

4.4 CONFIGURATION

4.4.1 AE Title/Presentation Address Mapping

4.4.1.1 Local AE Titles

The AE Title and the TCP/IP Port are configured using the Utility menu by the user.
The TCP/IP Address is configured using the Service Tool by the Field Service Engineer.

**Table 4.4-1
AE TITLE CONFIGURATION TABLE**

Application Entity	Default AE Title	Default TCP/IP Port
Storage SCU	UDR10A	Not Applicable
MWM SCU(Note)		
MPPS SCU(Note)		
Q/R SCU		
Print SCU		
Verification SCU		
Storage SCP		
Storage Commitment SCU	104	
Verification SCP		

**Table 4.4-2
AE TITLE CONFIGURATION TABLE FOR SECURE DICOM COMMUNICATION**

Application Entity	Default AE Title	Default TCP/IP Port
Storage SCU	UDR10A	Not Applicable
MWM SCU(Note)		
MPPS SCU(Note)		
Q/R SCU		
Print SCU		
Verification SCU		
Storage SCP	DCM_SECURE_LOCAL	2762
Storage Commitment SCU		
Verification SCP		

Each Secured AEs use the secure DICOM communication specified in 7.1.1 Secure Transport Connection Profiles. Other specification is same as non-secure AEs described in 4.2 AE Specifications.

Note: Set the same value for MWM SCU AE Title and MPPS SCU AE Title.

4.4.1.2 Remote AE Title / Presentation Address Mapping

The AE Titles and port numbers of remote applications are configured using the Service tool by the Field service engineer.

Secure communication settings can be configured for each IP address, port, host name and AE.

4.4.2 Parameters

A large number of parameters related to acquisition and general operation can be configured using the Service Tool. The table below only shows those configuration parameters relevant to DICOM communication. See the Product's Service Manual for details on general configuration capabilities.

**Table 4.4-3
CONFIGURATION PARAMETERS TABLE**

Parameter	Configurable (Yes/No) [Range]	Default Value
General Parameters		
Time-out waiting for an acceptance or rejection response to an Association Request (Application Level Timeout)	Yes [1-3600]	1 s
Time-out waiting for a response to an Association release request (Application Level Timeout)	No	15 s
Time-out waiting for completion of a TCP/IP connect request (Low-level timeout)	No	15 s
Time-out waiting for data between TCP/IP-packets (Low Level Timeout)	No	240 s
Supported Transfer Syntaxes	No	Implicit VR Little Endian Explicit VR Little Endian
Storage SCU Parameters		
Maximum number of simultaneously initiated Associations by the Storage SCU AE	No	1
Storage SCU time-out waiting for a response to a C-STORE-RQ	No	10,800 s
Number of times a failed send job may be retried	No	No limited
Delay between retrying failed send jobs	No	No retry
Storage Commitment SCU Parameters		
Maximum number of simultaneously initiated Associations by the Storage Commitment SCU AE	No	1
Modality Worklist SCU Parameters		
Maximum number of simultaneously initiated Associations by the MWM SCU AE	No	1
Modality Worklist SCU time-out waiting for the final response to a C-FIND-RQ	Yes [1-999]	20 s
Maximum number of Worklist Items	Yes [1-9999]	1000
Query Worklist for specific Scheduled Station AE Title	Yes [max. 16 characters]	UDR10A
Query Worklist for specific Modality Value	YES [RF,XA,CR,DX]	empty
MPPS SCU Parameters		
Maximum number of simultaneously initiated Associations by the MPPS SCU AE	No	1
MPPS SCU time-out waiting for a response to a N-CREATE-RQ	No	20 s
MPPS SCU time-out waiting for a response to a N-SET-RQ	No	20 s

Parameter	Configurable (Yes/No) [Range]	Default Value
Cycle time to retry when failure	No	N/A
Maximum number of retrying when failure	No	N/A
Q/R Parameters		
Maximum number of simultaneously initiated Associations by the Q/R SCU AE	No	1
Q/R Information Model	No	Study root
Storage SCP Parameters		
Maximum number of simultaneously initiated Associations by the Storage SCP AE	No	1
Print SCU Parameters		
Maximum number of simultaneously initiated Associations by the Print SCU AE	No	1
Print SCU time-out waiting for a response to a N-GET-RQ	No	180 s
Print SCU time-out waiting for a response to a N-CREATE-RQ	No	180 s
Print SCU time-out waiting for a response to a N-DELETE-RQ	No	180 s
Print SCU time-out waiting for a response to a N-SET-RQ	No	180 s
Print SCU time-out waiting for a response to a N-ACTION-RQ	No	180 s
Verification Parameters		
Cycle time of negotiation to Image Server(s) and Modality Worklist Server	No.	1 s

5. MEDIA INTERCHANGE

5.1 IMPLEMENTATION MODEL

5.1.1 Application Data Flow

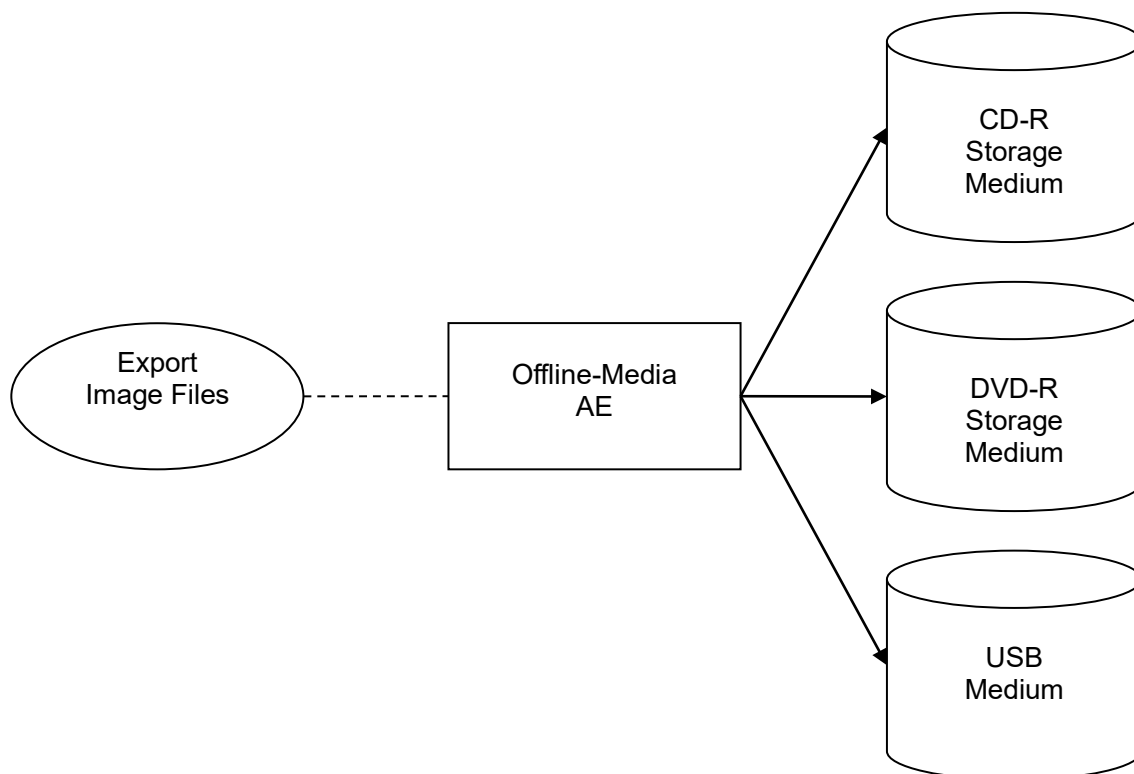

Figure 5.1-1
APPLICATION DATA FLOW DIAGRAM FOR MEDIA STORAGE

- The Offline-Media AE exports image files to a CD-R or DVD-R, an USB Storage medium. It is associated with the local real-world activity "Export Image Files" performed upon user request.

5.1.2 Functional Definition of AE

5.1.2.1 Functional Definition of Offline-Media AE

The Offline-Media AE is performed upon user request for the selected study to an offline DICOM CD-R, DVD-R or USB medium. It therefore performs the following tasks.

Export:

- Builds DICOM Information Objects.
- Creates a DICOMDIR file that represents the contents of the DICOM Information Objects to be recorded.
- Records DICOM Information Objects and the DICOMDIR file to the CD-R, the DVD-R or the USB medium.

5.1.3 Sequencing of Real-World Activities

5.1.3.1 Activity - Export Image Files to CD-R or DVD-R

Operator requests to create new Files-set(s) onto a CD-R or DVD-R. The requests are executed in the foreground.

The operations for "Export Image Files" are described below:

Step-1: Open the Patient/Study List.

Step-2: Select studies or images on the local storage device to be created to Export Image JOB.

Step-3: Insert the CD/DVD media in the device.

Step-4: Open the JOB control list.

Step-4: Request to write to the CD-R/DVD-R.

5.1.3.2 Activity - Export Image Files to USB media

Operator requests to create new Files-set(s) onto an USB media. The requests are placed in a queue and are executed in the background.

The operations for "Export Image Files" are described below:

Step-1: Select the database application.

Step-2: Select studies or images on the local storage device to be created to the USB medium.

Step-3: Insert the USB media in the device.

Step-4: Request to copy to the USB media.

5.1.4 File Meta Information for Implementation Class and Version

The implementation information written to the File Meta Header in each file is:

Table 5.1-1
DICOM IMPLEMENTATION CLASS AND VERSION FOR MEDIA STORAGE

File Meta Information Version	1
Implementation Class UID	1.2.392.200036.9116.32.5
Implementation Version Name	UDR10A

5.2 AE SPECIFICATIONS

5.2.1 Offline-Media AE Specification

The Offline-Media AE provides standard conformance to the DICOM Interchange Option of the Media Storage Service Class. The Application Profiles and roles are listed below:

**Table 5.2-1
APPLICATION PROFILES, ACTIVITIES, AND ROLES FOR OFFLINE-MEDIA**

Application Profiles Supported	Real World Activity	Role	SC Option
STD-GEN-CD, STD-GEN-DVD-JPEG, STD-GEN-USB-JPEG	Export Image Files	FSC	Interchange

5.2.1.1 File Meta Information for the Application Entity

The Source Application Entity Tile included in the File Meta Inform Header is below:

**Table 5.2-2
FILE META INFORMATION FOR OFFLINE-MEDIA**

Application Entity	Default AE Title
Offline-Media	UDR-10A

5.2.1.2 Real-World Activities

5.2.1.2.1 Activity - Export Image Files

The Offline-Media AE acts as an FSC using the interchange option when requested to export SOP Instances from the local database to a CD-R, a DVD-R or an USB medium.

5.2.1.2.1.1 Media Storage Application Profiles

The Offline-Media AE supports the STD-GEN-CD,STD-GEN-DVD-JPEG and the STD-GEN-USB-JPEG Application Profile.

5.2.1.2.1.2 Options

The Offline-Media AE supports the SOP Classes and Transfer Syntaxes listed in the table below for the STD-GEN-CD,STD-GEN-DVD-JPEG and the STD-GEN-USB-JPEG Application Profile as an FSC.

**Table 5.2-3
IODS, SOP CLASSES AND TRANSFER SYNTAXES FOR OFFLINE-MEDIA**

Information Object Definition	SOP Class UID	Transfer Syntax	Transfer Syntax UID
Media Storage Directory	1.2.840.10008.1.3.10	Explicit VR Little Endian Uncompressed	1.2.840.10008.1.2.1
XA Image	1.2.840.10008.5.1.4.1.1.12.1	Explicit VR Little Endian Uncompressed	1.2.840.10008.1.2.1

RF Image	1.2.840.10008.5.1.4.1.1.12.2	Explicit VR Little Endian Uncompressed	1.2.840.10008.1.2.1
Digital X-Ray Image Storage-For Presentation	1.2.840.10008.5.1.4.1.1.1.1	Explicit VR Little Endian Uncompressed	1.2.840.10008.1.2.1
Computed Radiography Image	1.2.840.10008.5.1.4.1.1.1	Explicit VR Little Endian Uncompressed	1.2.840.10008.1.2.1
Secondary Capture Image	1.2.840.10008.5.1.4.1.1.7	Explicit VR Little Endian Uncompressed	1.2.840.10008.1.2.1
X-Ray Radiation Dose SR	1.2.840.10008.5.1.4.1.1.88.67	Explicit VR Little Endian Uncompressed	1.2.840.10008.1.2.1

5.3 AUGMENTED AND PRIVATE APPLICATION PROFILES

5.3.1 Augmented Application Profiles

Not applicable to this product

5.3.2 Private Application Profiles

Not applicable to this product

5.4 MEDIA CONFIGURATION

Not applicable to this product

6. SUPPORT OF CHARACTER SETS

This product supports the following character sets:

- ISO-IR 6 (default) ISO646
- ISO-IR 87 (Japanese) JIS X 0208 (Kanji)

Character set ISO-IR 87 can be set to the tags listed in the Table below;

Table 6-1
Tag lists for ISO 2022 IR 87

Attribute Name	Tag	VR
Patient's Name	(0010,0010)	PN
Patient Comments	(0010,4000)	LT
Image Comments	(0020,4000)	LT
Performing Physician's Name	(0008,1050)	PN
Operators' Name	(0008,1070)	PN
Institution Name	(0008,0080)	LO
Institution Address	(0008,0081)	ST
Referring Physician's Name	(0008,0090)	PN
Study Description	(0008,1030)	LO
Series Description	(0008,103E)	LO
Institutional Department Name	(0008,1040)	LO
Requested Procedure Description	(0032,1060)	LO
Scheduled Procedure Step Description	(0040,0007)	LO
Performed Procedure Step Description	(0040,0254)	LO
Requesting Service	(0032,1033)	LO

Note:

Character set ISO-IR13(Japanese) is not support.

If the MWM SCU AE receives information that contain characters unsupported character sets, characters can be replaced to any characters.

If the Q/R SCU AE receives information that contain characters unsupported character sets, characters can be replaced to any characters.

These characters are not allowed.

'(,)', '<', '>', '=', '!', 'α', '¥', '*', '?', "=", "&&", "||"

7. SECURITY

The security section describes security features implemented by this product. It includes description of non-DICOM network protocols, information to configure firewalls and application whitelists, list of supported DICOM security profiles. Additionally, VPN, etc. are also specified in this security section.

7.1 DICOM Security Profile Availability

7.1.1 Secure Transport Connection Profiles

This product supports the following requirements for the secure DICOM communication. At the default configuration, the TLS option is deactivated.

**Table 7.1-1
SECURE TRANSPORT CONNECTION PROFILES**

Profile	Sender	Receiver	Reference
BCP195 TLS Secure Transport Connection	Y	Y	8.5.1
Non-Downgrading BCP195 TLS Secure Transport Connection	Y	Y	8.5.1
Extended BCP195 TLS Profile Secure Transport Connection	Y	Y	8.5.1

8. ANNEXES

8.1 IOD CONTENTS

8.1.1 Created SOP Instances

Table 8.1-1 specifies the attributes of a XA Image transmitted by the Storage SCU AE.

Table 8.1-2 specifies the attributes of a RF Image transmitted by the Storage SCU AE.

Table 8.1-3 specifies the attributes of a CR Image transmitted by the Storage SCU AE.

Table 8.1-4 specifies the attributes of a DX Image transmitted by the Storage SCU AE.

Table 8.1-5 specifies the attributes of a SC Image transmitted by the Storage SCU AE.

Table 8.1-6 specifies the attributes of a X-Ray Dose SR Transmitted by the Storage SCU AE .

The following tables use a number of abbreviations. The abbreviations used in the "Presence of ..." column are:

VNAP	Value Not Always Present (attribute sent zero length if no value is present)
ANAP	Attribute Not Always Present
ALWAYS	Always Present
EMPTY	Attribute is sent without a value
Not Present	All attributes in this module are not present

The abbreviations used in the "USAGE" column are:

M	the attribute value is Mandatory
C	the attribute value is Conditional
U	the attribute value is User Option

The abbreviations used in the "Source" column:

MWL	the attribute value source is from Modality Worklist
USER	the attribute value source is from User input
AUTO	the attribute value is generated automatically
MPPS	the attribute value is the same as that use for Modality Performed Procedure Step
CONFIG	the attribute value source is a configurable parameter

The abbreviations used in the "Value" column:

e.g.	the attribute value is example.
------	---------------------------------

8.1.1.1 XA Image IOD

**Table 8.1-1
IOD OF CREATED XA IMAGE SOP INSTANCES**

IE	Module	Reference	Presence of Module	Usage
Patient	Patient	Table 8.1-7	ALWAYS	M
Study	General Study	Table 8.1-8	ALWAYS	M
	Patient Study	Table 8.1-9	ALWAYS	U
Series	General Series	Table 8.1-10	ALWAYS	M
Equipment	General Equipment	Table 8.1-11	ALWAYS	M
Image	General Image	Table 8.1-12	ALWAYS	M
	Image Pixel	Table 8.1-13	ALWAYS	M
	Contrast/Bolus	Table 8.1-14	ANAP	C
	Cine	Table 8.1-15	ANAP	C
	Multi-frame	Table 8.1-16	ANAP	C
	X-Ray Image	Table 8.1-17	ALWAYS	M
	X-Ray Acquisition	Table 8.1-18	ALWAYS	M
	X-Ray Table	Table 8.1-19	ANAP	C
	XA Positioner	Table 8.1-20	ALWAYS	M
	DX Detector	Table 8.1-21	ANAP	U
	Modality LUT	Table 8.1-22	ALWAYS	C
	VOI LUT	Table 8.1-23	ALWAYS	U
	SOP Common	Table 8.1-24	ALWAYS	M

8.1.1.2 RF Image IOD

**Table 8.1-2
IOD OF CREATED RF IMAGE SOP INSTANCES**

IE	Module	Reference	Presence of Module	Usage
Patient	Patient	Table 8.1-7	ALWAYS	M
Study	General Study	Table 8.1-8	ALWAYS	M
	Patient Study	Table 8.1-9	ALWAYS	U
Series	General Series	Table 8.1-10	ALWAYS	M
Equipment	General Equipment	Table 8.1-11	ALWAYS	M
Image	General Image	Table 8.1-12	ALWAYS	M
	Image Pixel	Table 8.1-13	ALWAYS	M
	Contrast/Bolus	Table 8.1-14	ANAP	C
	Cine	Table 8.1-15	ANAP	C
	Multi-frame	Table 8.1-16	ANAP	C
	X-Ray Image	Table 8.1-17	ALWAYS	M
	X-Ray Acquisition	Table 8.1-18	ALWAYS	M
	X-Ray Table	Table 8.1-19	ANAP	U
	XRF Positioner	Table 8.1-25	ANAP	U
	DX Detector	Table 8.1-21	ANAP	U
	Modality LUT	Table 8.1-22	ALWAYS	C
	VOI LUT	Table 8.1-23	ALWAYS	U
	SOP Common	Table 8.1-24	ALWAYS	M

8.1.1.3 CR Image IOD

**Table 8.1-3
IOD OF CREATED CR IMAGE SOP INSTANCES**

IE	Module	Reference	Presence of Module	Usage
Patient	Patient	Table 8.1-7	ALWAYS	M
Study	General Study	Table 8.1-8	ALWAYS	M
	Patient Study	Table 8.1-9	ALWAYS	U
Series	General Series	Table 8.1-10	ALWAYS	M
	CR Series	Table 8.1-29	ALWAYS	M
Equipment	General Equipment	Table 8.1-11	ALWAYS	M
Image	General Image	Table 8.1-12	ALWAYS	M
	Image Pixel	Table 8.1-13	ALWAYS	M
	CR Image	Table 8.1-30	ALWAYS	M
	VOI LUT	Table 8.1-23	ALWAYS	U
	SOP Common	Table 8.1-24	ALWAYS	M

8.1.1.4 DX Image IOD

**Table 8.1-4
IOD OF CREATED DX IMAGE SOP INSTANCES**

IE	Module	Reference	Presence of Module	Usage
Patient	Patient	Table 8.1-7	ALWAYS	M
Study	General Study	Table 8.1-8	ALWAYS	M
	Patient Study	Table 8.1-9	ALWAYS	U
Series	General Series	Table 8.1-10	ALWAYS	M
	DX Series	Table 8.1-31	ALWAYS	M
Equipment	General Equipment	Table 8.1-11	ALWAYS	M
Image	General Image	Table 8.1-12	ALWAYS	M
	Image Pixel	Table 8.1-13	ALWAYS	M
	X-Ray Acquisition Dose	Table 8.1-32	ALWAYS	U
	DX Anatomy Imaged	Table 8.1-33	ANAP	M
	DX Image	Table 8.1-34	ALWAYS	M
	DX Detector	Table 8.1-21	ANAP	M
	X-Ray Tomography Acquisition	Table 8.1-26	ANAP	C
	VOI LUT	Table 8.1-23	ALWAYS	C
	Acquisition Context	Table 8.1-35	ALWAYS	M
	SOP Common	Table 8.1-24	ALWAYS	M

8.1.1.5 SC Image IOD

**Table 8.1-5
IOD OF CREATED SC IMAGE SOP INSTANCES**

IE	Module	Reference	Presence of Module	Usage
Patient	Patient	Table 8.1-7	ALWAYS	M
Study	General Study	Table 8.1-8	ALWAYS	M
	Patient Study	Table 8.1-9	ALWAYS	U
Series	General Series	Table 8.1-10	ALWAYS	M
Equipment	General Equipment	Table 8.1-11	ALWAYS	U
	SC Equipment	Table 8.1-27	ALWAYS	M
Image	General Image	Table 8.1-12	ALWAYS	M
	Image Pixel	Table 8.1-13	ALWAYS	M
	SC Image	Table 8.1-28	ALWAYS	M
	Modality LUT	Table 8.1-22	ALWAYS	C
	VOI LUT	Table 8.1-23	ALWAYS	U
	SOP Common	Table 8.1-24	ALWAYS	M

8.1.1.6 X-Ray Radiation Dose SR IOD

**Table 8.1-6
IOD OF CREATED X-RAY RADIATION DOSE SR INSTANCES**

IE	Module	Reference	Presence of Module	Usage
Patient	Patient	Table 8.1-7	ALWAYS	M
Study	General Study	Table 8.1-8	ALWAYS	M
	Patient Study	Table 8.1-9	ALWAYS	U
Series	SR Document Series	Table 8.1-36	ALWAYS	M
Equipment	General Equipment	Table 8.1-11	ALWAYS	M
	Enhanced General Equipment	Table 8.1-37	ALWAYS	M
Document	SR Document General	Table 8.1-38	ALWAYS	M
	SR Document Content	Table 8.1-40	ALWAYS	M
	SOP Common	Table 8.1-24	ALWAYS	M

8.1.1.7 Modules

**Table 8.1-7
PATIENT MODULE OF CREATED SOP INSTANCES**

Attribute Name	Tag	VR	Value	Presence of Value	Source
Patient's Name	(0010,0010)	PN	From Modality Worklist or user input or generated by device.(Note1) e.g. "NASU^TARO "	ALWAYS	MWL/ USER/ AUTO
Patient ID	(0010,0020)	LO	From Modality Worklist or user input or Generate. e.g. "00000001"	ALWAYS	MWL/ USER/ AUTO
Issuer of Patient ID	(0010,0021)	LO	From Modality Worklist	ANAP	MWL
Patient's Birth Date	(0010,0030)	DA	e.g. "20040103"	VNAP	MWL/ USER
Patient's Sex	(0010,0040)	CS	"M " or "F " or "O "	ALWAYS	MWL/ USER
Referenced Patient Sequence	(0008,1120)	SQ		ANAP	MWL
>Referenced SOP Class UID	(0008,1150)	UI		ANAP	MWL
>Referenced SOP Instance UID	(0008,1155)	UI		ANAP	MWL
Patient's Birth Time	(0010,0032)	TM		ANAP	MWL
Other Patient IDs	(0010,1000)	LO	e.g. "00000001"	ALWAYS	MWL/ USER/ AUTO
Other Patient Names	(0010,1001)	PN		ANAP	MWL
Ethnic Group	(0010,2160)	SH		ANAP	MWL
Patient Comments	(0010,4000)	LT	Comments of patient.	VNAP	MWL/ USER

Note1:63 characters maximum per component group.

**Table 8.1-8
GENERAL STUDY MODULE OF CREATED SOP INSTANCES**

Attribute Name	Tag	VR	Value	Presence of Value	Source
Study Instance UID	(0020,000D)	UI	From Modality Worklist or generated by device. e.g. "1.2.392.200036.9116.32.5.1.1.11 011921.20190129203615.100000 "	ALWAYS	MWL/ AUTO
Study Date	(0008,0020)	DA	<yyyymmdd> e.g. "20190129"	VNAP	AUTO
Study Time	(0008,0030)	TM	<hhmmss> e.g. "205620"	VNAP	AUTO
Referring Physician's Name	(0008,0090)	PN		VNAP	MWL/ U SER

Study Description	(0008,1030)	LO	Linked Protocol Name e.g. "UPPER GI"	ALWAYS	MWL/USER
Study ID	(0020,0010)	SH	Generated by device.	VNAP	AUTO
Accession Number	(0008,0050)	SH	From Modality Worklist or generated by device. e.g. "20190129-01-0001"	VNAP	MWL/AUTO
Requesting Service	(0032,1033)	LO		VNAP	AUTO

**Table 8.1-9
PATIENT STUDY MODULE OF CREATED SOP INSTANCES**

Attribute Name	Tag	VR	Value	Presence of Value	Source
Admitting Diagnoses Description	(0008,1080)	LO		ANAP	MWL
Admitting Diagnoses Code Sequence	(0008,1084)	SQ		ANAP	MWL
> Code Value	(0008,0100)	SH		ANAP	MWL
> Coding Scheme Designator	(0008,0102)	SH		ANAP	MWL
> Coding Scheme Version	(0008,0103)	SH		ANAP	MWL
> Code Meaning	(0008,0104)	LO		ANAP	MWL
Patient's Age	(0010,1010)	AS		ANAP	MWL/AUTO
Patient's Size	(0010,1020)	DS		ANAP	MWL
Patient's Weight	(0010,1030)	DS		ANAP	MWL
Allergies	(0010,2110)	LO		ANAP	MWL
Smoking Status	(0010,21A0)	CS		ANAP	MWL
Pregnancy Status	(0010,21C0)	US	From Modality Worklist e.g. "0001" (not pregnant)	ANAP	MWL
Last Menstrual Date	(0010,21D0)	DA		ANAP	MWL
Patient State	(0038,0500)	LO		ANAP	MWL
Occupation	(0010,2180)	SH		ANAP	MWL
Additional Patient History	(0010,21B0)	LT		ANAP	MWL
Admission ID	(0038,0010)	LO		ANAP	MWL

**Table 8.1-10
GENERAL SERIES MODULE OF CREATED SOP INSTANCES**

Attribute Name	Tag	VR	Value	Presence of Value	Source
Modality	(0008,0060)	CS	e.g. "XA"	ALWAYS	CONFIG
Series Instance UID	(0020,000E)	UI	Generated by Device. e.g. 1.2.392.200036.9116.32.5.1.1.110 11921.20190129203615.100000.1 "	ALWAYS	AUTO
Series Number	(0020,0011)	IS	Generated sequential number from study start. e.g. "1 "	VNAP	AUTO
Laterality	(0020,0060)	CS		EMPTY	AUTO
Series Date	(0008,0021)	DA	e.g. "20190129"	ALWAYS	AUTO
Series Time	(0008,0031)	TM	e.g. "205620"	ALWAYS	AUTO
Performing Physician's Name	(0008,1050)	PN		VNAP	MWL/USER
Operators' Name	(0008,1070)	PN		ALWAYS	USER
Body Part Examined	(0018,0015)	CS	e.g. "ABDOMEN " Text description of the part of the body examined. Defined Terms: SKULL,CSPINE,TSPINE,LSPINE, SSPINE,COCCYX,CHEST, CLAVICLE,BREAST,ABDOMEN, PELVIS,HIP,SHOULDER,ELBOW, KNEE,ANKLE,HAND,FOOT, EXTREMITY,HEAD,HEART, NECK,LEG,ARM,JAW	ALWAYS	MWL/USER
Protocol Name	(0018,1030)	LO		ALWAYS	MWL/USER

**Table 8.1-11
GENERAL EQUIPMENT MODULE OF CREATED SOP INSTANCES**

Attribute Name	Tag	VR	Value	Presence of Value	Source
Manufacturer	(0008,0070)	LO	"CANON_MEC"	ALWAYS	AUTO
Institution Name	(0008,0080)	LO	From System Configuration. e.g. "CANON HOSP" (Note1)	VNAP	CONFIG
Institution Address	(0008,0081)	ST		VNAP	CONFIG
Station Name	(0008,1010)	SH	e.g. "RADIO ROOM-1"	VNAP	CONFIG
Institutional Department Name	(0008,1040)	LO	e.g. "DEPARTMENT" (Note1)	VNAP	CONFIG
Manufacturer's Model Name	(0008,1090)	LO	"UDR-10A"	ALWAYS	AUTO
Device Serial Number	(0018,1000)	LO	e.g. "A0123456"	ALWAYS	AUTO
Software Versions	(0018,1020)	LO	e.g. "V2.5 SP0000 "	ALWAYS	AUTO

Note1:Max 30 characters.

**Table 8.1-12
GENERAL IMAGE MODULE OF CREATED SOP INSTANCES**

Attribute Name	Tag	VR	Value	Presence of Value	Source
Instance Number	(0020,0013)	IS	Generated sequential number from series start. e.g. "1 "	ALWAYS	AUTO
Patient Orientation	(0020,0020)	CS	e.g. "R\H"	VNAP	USER
Content Date	(0008,0023)	DA	e.g. "20190129"	ALWAYS	AUTO
Content Time	(0008,0033)	TM	e.g. "205620"	ALWAYS	AUTO
Image Type	(0008,0008)	CS		ALWAYS	AUTO
Acquisition Date	(0008,0022)	DA	e.g. "20190129"	ALWAYS	AUTO
Acquisition Time	(0008,0032)	TM	e.g. "205620"	ALWAYS	AUTO
Presentation LUT Shape	(2050,0020)	CS	e.g. "IDENTITY"	ALWAYS	AUTO
Irradiation Event UID	(0008,3010)	UI	Generated by device.	ALWAYS	AUTO

**Table 8.1-13
IMAGE PIXEL MODULE OF CREATED SOP INSTANCES**

Attribute Name	Tag	VR	Value	Presence of Value	Source
Samples per Pixel	(0028,0002)	US	1	ALWAYS	AUTO
Photometric Interpretation	(0028,0004)	CS	e.g. "MONOCHROME2 ", "RGB "	ALWAYS	AUTO
Rows	(0028,0010)	US	e.g. "3072", "2688" etc.	ALWAYS	AUTO
Columns	(0028,0011)	US	e.g. "3072", "2688" etc.	ALWAYS	AUTO
Bits Allocated	(0028,0100)	US	e.g. "16"	ALWAYS	AUTO
Bits Stored	(0028,0101)	US	e.g. "16", "12", "8"	ALWAYS	CONFIG
High Bit	(0028,0102)	US	e.g. "15 ", "11", "7"	ALWAYS	CONFIG
Pixel Representation	(0028,0103)	US	0	ALWAYS	AUTO
Pixel Data	(7FE0,0010)	OW		ALWAYS	AUTO

**Table 8.1-14
CONTRAST/BOLUS MODULE OF CREATED SOP INSTANCES**

Attribute Name	Tag	VR	Value	Presence of Value	Source
Contrast/Bolus Agent	(0018,0010)	LO		ANAP	CONFIG

**Table 8.1-15
CINE MODULE OF CREATED SOP INSTANCES**

Attribute Name	Tag	VR	Value	Presence of Value	Source
Frame Time	(0018,1063)	DS		ANAP	AUTO
Cine Rate	(0018,0040)	IS		ANAP	AUTO

**Table 8.1-16
MULTI-FRAME MODULE OF CREATED SOP INSTANCES**

Attribute Name	Tag	VR	Value	Presence of Value	Source
Number of Frames	(0028,0008)	IS		VNAP	AUTO
Frame Increment Pointer	(0028,0009)	AT		VNAP	AUTO

**Table 8.1-17
X-RAY IMAGE MODULE OF CREATED SOP INSTANCES**

Attribute Name	Tag	VR	Value	Presence of Value	Source
Frame Increment Pointer	(0028,0009)	AT		VNAP	AUTO
Image Type	(0008,0008)	CS	e.g. "ORIGINAL\PRIMARY"	ANAP	AUTO
Pixel Intensity Relationship	(0028,1040)	CS	e.g. "DISP"	ANAP	AUTO
Samples per Pixel	(0028,0002)	US	e.g. 1	ALWAYS	AUTO
Photometric Interpretation	(0028,0004)	CS	e.g. "MONOCHROME2 "	ALWAYS	AUTO
Bits Allocated	(0028,0100)	US	e.g. "16"	ALWAYS	AUTO
Bits Stored	(0028,0101)	US	e.g. "16","12"	ALWAYS	CONFIG
High Bit	(0028,0102)	US	e.g. "15 ","11"	ALWAYS	CONFIG
Pixel Representation	(0028,0103)	US	0	ALWAYS	AUTO

**Table 8.1-18
X-RAY ACQUISITION MODULE OF CREATED SOP INSTANCES**

Attribute Name	Tag	VR	Value	Presence of Value	Source
KVP	(0018,0060)	DS		ALWAYS	AUTO
Radiation Setting	(0018,1155)	CS	e.g. "GR" or "SC"	ALWAYS	AUTO
X-Ray Tube Current	(0018,1151)	IS	e.g. "58"	ALWAYS	AUTO
X-Ray Tube Current in uA	(0018,8151)	DS	e.g. "58000"	ALWAYS	AUTO
Exposure Time	(0018,1150)	IS	e.g. "24"	ANAP	AUTO

Exposure Time in uS	(0018,8150)	DS	e.g. "24000"	ANAP	AUTO
Average Pulse Width	(0018,1154)	DS		ANAP	AUTO
Radiation Mode	(0018,115A)	CS	e.g. "CONTINUOUS" or "PULSED"	ANAP	AUTO
Intensifier Size	(0018,1162)	DS	e.g. 430	ALWAYS	CONF G
Field of View Shape	(0018,1147)	CS	"RECTANGLE"	ALWAYS	AUTO
Field of View Dimension(s)	(0018,1149)	IS	e.g. "342\342"	ALWAYS	AUTO
Imager Pixel Spacing	(0018,1164)	DS	e.g. "0.160\0.160"	ALWAYS	AUTO
Pixel Spacing	(0028,0030)	DS	e.g. "0.160\0.160"	ANAP	AUTO
Image and Fluoroscopy Area Dose Product	(0018,115E)	DS	e.g. 0.180	ANAP	AUTO

**Table 8.1-19
X-RAY TABLE MODULE OF CREATED SOP INSTANCES**

Attribute Name	Tag	VR	Value	Presence of Value	Source
Table Motion	(0018,1134)	CS	e.g. "STATIC" or "DYNAMIC"	ALWAYS	AUTO
Table Vertical Increment	(0018,1135)	DS		ANAP	AUTO
Table Longitudinal Increment	(0018,1137)	DS		ANAP	AUTO
Table Lateral Increment	(0018,1136)	DS		ANAP	AUTO
Table Angle	(0018,1138)	DS		ANAP	AUTO

**Table 8.1-20
XA POSITIONER MODULE OF CREATED SOP INSTANCES**

Attribute Name	Tag	VR	Value	Presence of Value	Source
Distance Source to Detector	(0018,1110)	DS	e.g. 1100	ALWAYS	AUTO
Distance Source to Patient	(0018,1111)	DS		ALWAYS	AUTO
Estimated Radiographic Magnification Factor	(0018,1114)	DS		ANAP	AUTO
Positioner Primary Angle	(0018,1510)	DS		ANAP	AUTO
Positioner Secondary Angle	(0018,1511)	DS		ANAP	AUTO

**Table 8.1-21
DX DETECTOR MODULE OF CREATED SOP INSTANCES**

Attribute Name	Tag	VR	Value	Presence of Value	Source
Detector Type	(0018,7004)	CS		EMPTY	AUTO
Imager Pixel Spacing	(0018,1164)	DS		EMPTY	AUTO
Exposure Index	(0018,1411)	DS		ANAP	AUTO
Target Exposure Index	(0018,1412)	DS		ANAP	AUTO
Deviation Index	(0018,1413)	DS		ANAP	AUTO
Field of View Shape	(0018,1147)	CS	"RECTANGLE"	ALWAYS	AUTO
Field of View Dimension(s)	(0018,1149)	IS	e.g. "342\342"	ALWAYS	AUTO

Imager Pixel Spacing	(0018,1164)	DS	e.g. "0.160\0.160"	ANAP	AUTO
Pixel Spacing	(0028,0030)	DS	e.g. "0.160\0.160"	ANAP	AUTO

**Table 8.1-22
MODALITY LUT MODULE OF CREATED SOP INSTANCES**

Attribute Name	Tag	VR	Value	Presence of Value	Source
Rescale Intercept	(0028,1052)	DS	e.g. "0"	ANAP	AUTO
Rescale Slope	(0028,1053)	DS	e.g. "1"	ANAP	AUTO
Rescale Type	(0028,1054)	LO	e.g. "US"	ANAP	AUTO

**Table 8.1-23
VOI LUT MODULE OF CREATED SOP INSTANCES**

Attribute Name	Tag	VR	Value	Presence of Value	Source
Window Center	(0028,1050)	DS	e.g. 32768	ANAP	AUTO
Window Width	(0028,1051)	DS	e.g. 65535	ANAP	AUTO

**Table 8.1-24
SOP COMMON MODULE OF CREATED SOP INSTANCES**

Attribute Name	Tag	VR	Value	Presence of Value	Source
SOP Class UID	(0008,0016)	UI	SOP Class UID value for this created instance. e.g. "1.2.840.10008.5.1.4.1.1.12.1" for XA Image Other value to be set is described in Table 4.2 1 SOP CLASSES FOR THE STORAGE SCU AE.	ALWAYS	AUTO
SOP Instance UID	(0008,0018)	UI	e.g. "1.2.392.200036.9116.32.5.1.1.11011921.20160129203615.120000"	ALWAYS	MWL/AUTO
Specific Character Set	(0008,0005)	CS	"ISO 2022 IR 87"	ANAP	CONFIG

**Table 8.1-25
XRF POSITIONER MODULE OF CREATED SOP INSTANCES**

Attribute Name	Tag	VR	Value	Presence of Value	Source
Distance Source to Detector	(0018,1110)	DS	e.g. 1100	ALWAYS	AUTO
Distance Source to Patient	(0018,1111)	DS		ANAP	AUTO
Estimated Radiographic Magnification Factor	(0018,1114)	DS		ANAP	AUTO
Column Angulation	(0018,1450)	DS		ANAP	AUTO

**Table 8.1-26
X-RAY TOMOGRAPHY ACQUISITION MODULE OF CREATED SOP INSTANCES**

Attribute Name	Tag	VR	Value	Presence of Value	Source
Tomo Layer Height	(0018,1460)	DS		VNAP	AUTO
Tomo Angle	(0018,1470)	DS		VNAP	AUTO
Tomo Time	(0018,1480)	DS		VNAP	AUTO
Tomo Type	(0018,1490)	CS		VNAP	AUTO
Tomo Class	(0018,1491)	CS	e.g. "TOMOSYNTHESIS"	VNAP	AUTO
Number of Tomosynthesis Source Images	(0018,1495)	IS		VNAP	AUTO

**Table 8.1-27
SC EQUIPMENT MODULE OF CREATED SOP INSTANCES**

Attribute Name	Tag	VR	Value	Presence of Value	Source
Conversion Type	(0008,0064)	CS	e.g. "WSD"	ANAP	AUTO

**Table 8.1-28
SC IMAGE MODULE OF CREATED SOP INSTANCES**

Attribute Name	Tag	VR	Value	Presence of Value	Source
Date of Secondary Capture	(0018,1012)	DA	e.g. "20190129"	ANAP	AUTO
Time of Secondary Capture	(0018,1014)	TM	e.g. "205620"	ANAP	AUTO

**Table 8.1-29
CR SERIES MODULE OF CREATED CR IMAGE SOP INSTANCES**

Attribute Name	Tag	VR	Value	Presence of Value	Source
Body Part Examined	(0018,0015)	CS	e.g. "ABDOMEN " Text description of the part of the body examined. Defined Terms: SKULL,CSPINE,TSPINE LSPINE,SSPINE, COCCYX,CHEST, CLAVICLE,BREAST ABDOMEN,PELVIS,HIP SHOULDER,ELBOW KNEE,ANKLE,HAND FOOT,EXTREMITY, HEAD,HEART,NECK,LEG ARM,JAW	ALWAYS	MWL/USER
View Position	(0018,5101)	CS		EMPTY	AUTO

**Table 8.1-30
CR IMAGE MODULE OF CREATED CR IMAGE SOP INSTANCES**

Attribute Name	Tag	VR	Value	Presence of Value	Source
Photometric Interpretation	(0028,0004)	CS	"MONOCHROME2 "	ALWAYS	AUTO
KVP	(0018,0060)	DS		ANAP	AUTO
Distance Source to Detector	(0018,1110)	DS	e.g. 1100	ALWAYS	AUTO
Exposure Time	(0018,1150)	IS	e.g. "24"	ANAP	AUTO
X-Ray Tube Current	(0018,1151)	IS	e.g. "58"	ANAP	AUTO
Exposure	(0018,1152)	IS	e.g. "52"	ANAP	AUTO
Imager Pixel Spacing	(0018,1164)	DS	e.g. "0.160\0.160"	ANAP	AUTO
Pixel Spacing	(0028,0030)	DS	e.g. "0.160\0.160"	ANAP	AUTO
Imager Pixel Spacing	(0018,1164)	DS		ANAP	AUTO
Exposure Index	(0018,1411)	DS		ANAP	AUTO
Target Exposure Index	(0018,1412)	DS		ANAP	AUTO
Deviation Index	(0018,1413)	DS		ANAP	AUTO

**Table 8.1-31
DX SERIES MODULE OF CREATED DX IMAGE SOP INSTANCES**

Attribute Name	Tag	VR	Value	Presence of Value	Source
Modality	(0008,0060)	CS	e.g. "DX"	ALWAYS	AUTO
Presentation Intent Type	(0008,0068)	CS	e.g. "FOR PRESENTATION"	ALWAYS	AUTO

**Table 8.1-32
X-RAY ACQUISITION DOSE MODULE OF CREATED DX IMAGE SOP INSTANCES**

Attribute Name	Tag	VR	Value	Presence of Value	Source
KVP	(0018,0060)	DS		ANAP	AUTO
Distance Source to Detector	(0018,1110)	DS	e.g. 1100	ALWAYS	AUTO
Exposure Time	(0018,1150)	IS	e.g. "24"	ANAP	AUTO
X-Ray Tube Current	(0018,1151)	IS	e.g. "58"	ANAP	AUTO
Exposure	(0018,1152)	IS	e.g. "52"	ANAP	AUTO
Entrance Dose in mGy	(0040,8302)	DS		ANAP	AUTO

**Table 8.1-33
DX ANATOMY IMAGED MODULE OF CREATED DX IMAGE SOP INSTANCES**

Attribute Name	Tag	VR	Value	Presence of Value	Source
Image Laterality	(0020,0062)	CS	Laterality of body part examined. U = unpaired	ALWAYS	AUTO
Anatomic Region Sequence	(0008,2218)	SQ		EMPTY	AUTO

**Table 8.1-34
DX IMAGE MODULE OF CREATED DX IMAGE SOP INSTANCES**

Attribute Name	Tag	VR	Value	Presence of Value	Source
Image Type	(0008,0008)	CS	e.g. "ORIGINAL\PRIMARY"	ANAP	AUTO
Samples per Pixel	(0028,0002)	US	e.g. 1	ALWAYS	AUTO
Photometric Interpretation	(0028,0004)	CS	e.g. "MONOCHROME2 "	ALWAYS	AUTO
Bits Allocated	(0028,0100)	US	e.g. "16"	ALWAYS	AUTO
Bits Stored	(0028,0101)	US	e.g. "16","12"	ALWAYS	CONF I G
High Bit	(0028,0102)	US	e.g. "15 ","11"	ALWAYS	CONF I G
Pixel Representation	(0028,0103)	US	0	ALWAYS	AUTO
Pixel Intensity Relationship	(0028,1040)	CS	"LIN"	ALWAYS	AUTO
Pixel Intensity Relationship Sign	(0028,1041)	SS	-1	ALWAYS	AUTO
Rescale Intercept	(0028,1052)	DS	0	ALWAYS	AUTO
Rescale Slope	(0028,1053)	DS	1	ALWAYS	AUTO
Rescale Type	(0028,1054)	LO	"US"	ALWAYS	AUTO
Presentation LUT Shape	(2050,0020)	CS	e.g. "IDENTITY"	ALWAYS	AUTO
Lossy Image Compression	(0028,2110)	CS	"00"	ALWAYS	AUTO
Patient Orientation	(0020,0020)	CS	e.g. "R\H"	ALWAYS	USER
Burned In Annotation	(0028,0301)	CS	e.g. "NO"	ANAP	AUTO
Window Center	(0028,1050)	DS	e.g. 32768	ANAP	AUTO
Window Width	(0028,1051)	DS	e.g. 65535	ANAP	AUTO

**Table 8.1-35
ACQUISITION CONTEXT MODULE OF CREATED DX IMAGE SOP INSTANCES**

Attribute Name	Tag	VR	Value	Presenc e of Value	Source
Acquisition Context Sequence	(0040,0555)	SQ		EMPTY	AUTO

**Table 8.1-36
SR DOCUMENT SERIES MODULE OF CREATED X-RAY RADIATION DOSE SR SOP INSTANCES**

Attribute Name	Tag	VR	Value	Presenc e of Value	Source
Modality	(0008,0060)	CS	e.g. "SR"	ALWAYS	AUTO
Series Instance UID	(0020,000E)	UI	Generated by Device. e.g. "1.2.392.200036.9116.32.5.1.1.11 011921.20190129203615.100000. 9001 "	ALWAYS	AUTO
Series Number	(0020,0011)	IS	e.g. "9001 "	VNAP	AUTO
Series Date	(0008,0021)	DA	e.g. "20190129"	ALWAYS	AUTO
Series Time	(0008,0031)	TM	e.g. "205620"	ALWAYS	AUTO

Protocol Name	(0018,1030)	LO		ALWAYS	MWL/USER
---------------	-------------	----	--	--------	----------

**Table 8.1-37
ENHANCED GENERAL EQUIPMENT MODULE OF CREATED X-RAY RADIATION DOSE SR SOP
INSTANCES**

Attribute Name	Tag	VR	Value	Presence of Value	Source
Manufacturer	(0008,0070)	LO	"CANON_MEC"	ALWAYS	AUTO
Manufacturer's Model Name	(0008,1090)	LO	"UDR-10A"	ALWAYS	AUTO
Device Serial Number	(0018,1000)	LO	e.g. "A0123456"	ALWAYS	AUTO
Software Versions	(0018,1020)	LO	e.g. "V2.5 SP0000 "	ALWAYS	AUTO

Note1:Max 30 characters.

**Table 8.1-38
SR DOCUMENT GENERAL MODULE OF CREATED X-RAY RADIATION DOSE SR SOP INSTANCES**

Attribute Name	Tag	VR	Value	Presence of Value	Source
Instance Number	(0020,0013)	IS	e.g. "1 "	ALWAYS	AUTO
Completion Flag	(0040,A491)	CS	"COMPLETE"	ALWAYS	AUTO
Verification Flag	(0040,A493)	CS	"UNVERIFIED"	ALWAYS	AUTO
Content Date	(0008,0023)	DA	e.g. "20190129"	ALWAYS	AUTO
Content Time	(0008,0033)	TM	e.g. "205620"	ALWAYS	AUTO
Current Requested Procedure Evidence Sequence	(0040,A375)	SQ		VNAP	AUTO
> Study Instance UID	(0020,000D)	UI		ALWAYS	MWL/AUTO
> Referenced Series Sequence	(0008,1115)	SQ		VNAP	AUTO
>>Series Instance UID	(0020,000E)	UI	Generated by Device. e.g. "1.2.392.200036.9116.32.5.1.1.1 1011921.20190129203615.1000 00.9001 "	ALWAYS	AUTO
>>Referenced SOP Sequence	(0008,1199)	SQ		VNAP	AUTO
>>>Referenced SOP Class UID	(0008,1150)	UI	Generated by Device.	ALWAYS	AUTO
>>>Referenced SOP Instance UID	(0008,1155)	UI		ALWAYS	AUTO

8.1.2 Usage of Attributes from received IOD's

No SOP Class specific fields are required.

8.1.3 Attribute Mapping

The relationships between attributes received via Modality Worklist, stored in acquired images and communicated via MPPS are summarized in Table 8.1-39.

**Table 8.1-39
ATTRIBUTE MAPPING BETWEEN MODALITY WORKLIST, IMAGE AND MPPS**

Modality Worklist	Image IOD	MPPS IOD
Study Instance UID	Study Instance UID	Scheduled Step Attributes Sequence >Study Instance UID
Accession Number	Accession Number	Scheduled Step Attributes Sequence >Accession Number
Requested Procedure ID	--	Scheduled Step Attributes Sequence >Requested Procedure ID
Requested Procedure Description	--	Scheduled Step Attributes Sequence >Requested Procedure Description
	Protocol Name(Note1)	--
Scheduled Procedure Step Sequence > Scheduled Procedure Step Description	--	Scheduled Step Attributes Sequence >Scheduled Procedure Step Description
		Performed Procedure Step Description
--	Study Description	
Scheduled Procedure Step Sequence > Scheduled Procedure Step ID	--	Scheduled Step Attributes Sequence(Note 4) >Scheduled Procedure Step ID
Scheduled Procedure Step Sequence > Scheduled Protocol Code Sequence	--	Performed Protocol Code Sequence
Scheduled Procedure Step Sequence > Scheduled Procedure Step ID	--	Performed Procedure Step ID
--	Study date	Performed Procedure Step Start Date
--	Study Time	Performed Procedure Step Start Time
Referring Physician's Name	--	--

--	Referring Physician's Name(Note2)	
Requesting Physician's Name	--	
--	Performing Physician's Name(Note3)	Performing Physician's Name
Scheduled Performing Physician's Name		
Requesting Service	Requesting Service	--
	--	
Patient Name	Patient Name	Patient Name
Patient's ID	Patient's ID	Patient's ID
Patient's Birth Date	Patient's Birth Date	Patient's Birth Date
Patient's Sex	Patient's Sex	Patient's Sex
Patient Comments	Patient Comments	--
--	Operator's Name	Operator's Name

This table shows only typical data sets.

Other data sets are also set as default settings.

Note1: The value entered from the worklist will be used as a key to search for the "protocol name" in the device. Depending on the service engineer's settings, you can switch the search key from the requested step description or the scheduled step description. Depending on the setting, the Default value will be used instead of the Worklist value.

Note2: The value is copied from the TAG according to setting.

Note3: The value is copied from the TAG according to setting.

Note4: Mapping only the contents of the first Scheduled Procedure Step included in the MWM.

8.1.4 Coerced/Modified Fields

When an image with a value of (0028,0008) greater than 1 is received, it cannot be displayed.

8.1.5 Structured Report Document Information

8.1.5.1 X-ray Radiation Dose Report

8.1.5.1.1 Template Structure

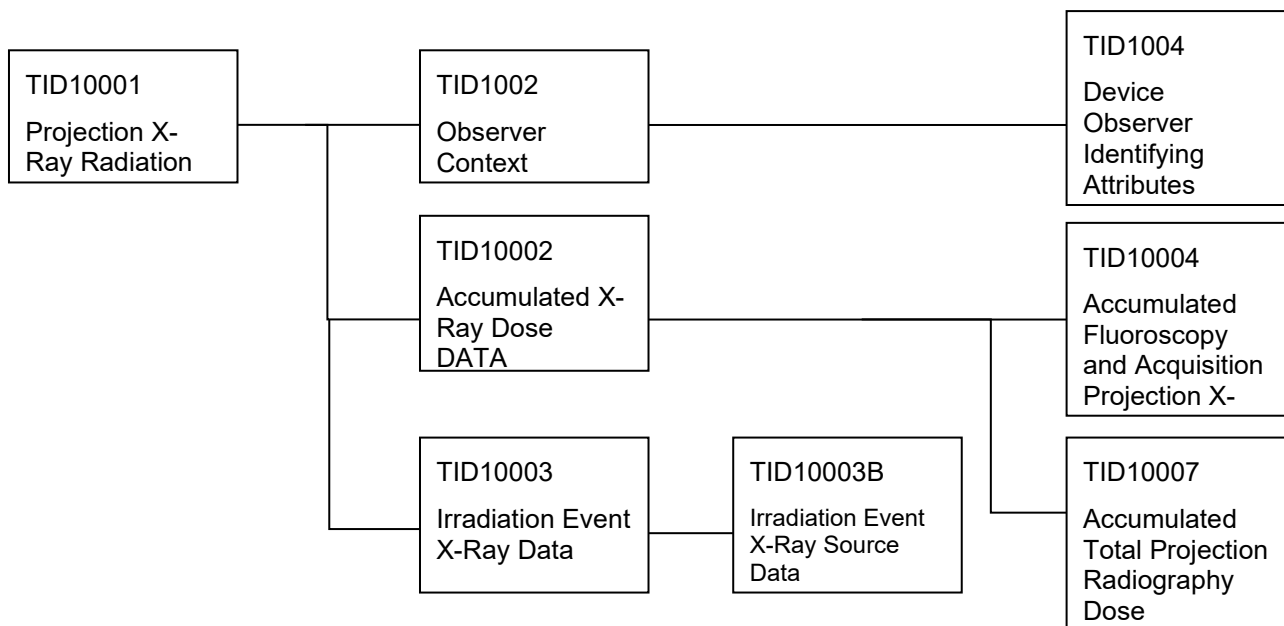

8.1.5.1.1.1 TID10001 Projection X-Ray Radiation Dose

Table 8.1-40
PROJECTION X-RAY RADIATION DOSE

NL	Rel with Parent	Concept Name	V M	Presence of Value	Value
		EV (113701, DCM, "X-Ray Radiation Dose Report")	1	ANAP	AUTO
>	HAS CONCEPT MOD	EV (121058, DCM, "Procedure reported")	1	ALWAYS	DT (113704, DCM, "Projection X-Ray")
>>	HAS CONCEPT MOD	EV (G-C0E8, SRT, "Has Intent")	1	ALWAYS	EV (R-408C3,SRT,"Diagnostic Intent")
>		TID 1002 OBSERVER CONTEXT	1	ALWAYS	
>	HAS OBS CONTEXT	EV (113705, DCM, "Scope of Accumulation")	1	ALWAYS	EV(113014, DCM, "Study")
>>	HAS PROPERTIES	EV (110180, DCM, "Study Instance UID")	1	ALWAYS	AUTO
>	CONTAINS	DTID 10002 "Accumulated X-Ray Dose"	1	ALWAYS	(113622, DCM, "Single Plane")
>	CONTAINS	DTID 10003 "Irradiation Event X-Ray Data"	1-n	ALWAYS	

>	CONTAINS	EV (113854, DCM, "Source of Dose Information")	1-n	ALWAYS	(113856, DCM, "Automated Data Collection")
---	----------	--	-----	--------	--

8.1.5.1.1.2 TID1002 OBSERVER CONTEXT

Table 8.1-41
OVSERVER CONTEXT

NL	Rel with Parent	Concept Name	V M	Presence of Value	Value
	HAS OBS CONTEXT	EV (121005, DCM, "Observer Type")	1	ALWAYS	(121007, DCM, "Device")
	HAS OBS CONTEXT	DTID 1004 "Device Observer Identifying Attributes"	1	ALWAYS	

8.1.5.1.1.3 TID1004 DEVICE OBSERVER IDENTIFYING ATTRIBUTES

Table 8.1-42
DEVICE OBSERVER IDENTIFYING ATTRIBUTES

NL	Rel with Parent	Concept Name	V M	Presence of Value	Value
		EV (121012, DCM, "Device Observer UID")	1	ALWAYS	Device UID (0018,1002) in General Equipment Module
		EV (121014, DCM, "Device Observer Manufacturer")	1	ANAP	Manufacturer (0008,0070) in General Equipment Module
		EV (121015, DCM, "Device Observer Model Name")	1	ANAP	Manufacturer's Model Name (0008,1090) in General Equipment Module
		EV (121016, DCM, "Device Observer Serial Number")	1	ANAP	Device Serial Number (0018,1000) in General Equipment Module

8.1.5.1.1.4 TID10002 ACCUMULATED X-RAY DOSE

Table 8.1-43
ACCUMULATED X-RAY DOSE

NL	Rel with Parent	Concept Name	V M	Presence of Value	Value
	CONTAINER	EV (113702, DCM, "Accumulated X-Ray Dose Data")	1	ANAP	
>	CODE	EV (113764, DCM, "Acquisition Plane")	1	ALWAYS	(113622, DCM, "Single Plane")
>	INCLUDE	DTID 10004 "Accumulated Fluoroscopy and Acquisition Projection X-Ray Dose"	1	ALWAYS	

>	CONTAINS	DTID 10007 "Accumulated Total Projection Radiography Dose"	1	ALWAYS	
---	----------	--	---	--------	--

8.1.5.1.1.5 TID10003 IRRADIATION EVENT X-RAY DATA

Table 8.1-44
IRRADIATION EVENT X-RAY DATA

NL	Rel with Parent	Concept Name	V M	Presence of Value	Value
		EV (113706, DCM, "Irradiation Event X-Ray Data")	1		
>	HAS CONCEPT MOD	EV (113764, DCM, "Acquisition Plane")	1	ALWAYS	(113622, DCM, "Single Plane")
>	CONTAINS	EV (113769, DCM, "Irradiation Event UID")	1	ALWAYS	
>	CONTAINS	DT (111526, DCM, "DateTime Started")	1	ANAP	
>	CONTAINS	EV (113721, DCM, "Irradiation Event Type")	1	ANAP	(4491008, SCT, "Fluoroscopy") (113611, DCM, "Stationary Acquisition")
>	CONTAINS	EV (125203, DCM, "Acquisition Protocol")	1	ALWAYS	
>	CONTAINS	EV (123014, DCM, "Target Region")	1	ALWAYS	DCID 4031 "Common Anatomic Regions"
>	CONTAINS	EV (122130, DCM, "Dose Area Product")	1	ALWAYS	UNITS = EV (Gy.m2, UCUM, "Gy.m2")
>	CONTAINS	DTID 10003B "Irradiation Event X-Ray Source Data"	1	ALWAYS	

8.1.5.1.1.6 TID10003B IRRADIATION EVENT X-RAY SOURCE DATA

**Table 8.1-45
IRRADIATION EVENT X-RAY DATA**

NL	Rel with Parent	Concept Name	V M	Presence of Value	Value
		EV (113738, DCM, "Dose (RP) ")	1	ALWAYS	UNITS = EV (Gy, UCUM, "Gy")
		EV (113780, DCM, "Reference Point Definition")	1	ALWAYS	AUTO
		EV (113732, DCM, "Fluoro Mode")	1	VNAP	DCID 10004 "Fluoro Modes"
		EV (113791, DCM, "Pulse Rate")	1	VNAP	UNITS = EV ({pulse}/s, UCUM, "pulse/s")
		EV (113768, DCM, "Number of Pulses")	1	VNAP	UNITS = EV (1, UCUM, "no units")
		EV (113793, DCM, "Pulse Width")	1-n	VNAP	UNITS = EV (ms, UCUM, "ms")
		EV (113742, DCM, "Irradiation Duration")	1	VNAP	UNITS = EV (s, UCUM, "s")
		EV (113733, DCM, "KVP")	1-n	ALWAYS	UNITS = EV (kV, UCUM, "kV")
		EV (113734, DCM, "X-Ray Tube Current")	1-n	ALWAYS	UNITS = EV (mA, UCUM, "mA")
		EV (113824, DCM, "Exposure Time")	1	ALWAYS	UNITS = EV (ms, UCUM, "ms") Note1
		EV (113771, DCM, "X-Ray Filters")	1-n	VNAP	
>	CONTAINS	EV (113772, DCM, "X-Ray Filter Type")	1	VNAP	DCID 10007 "X-Ray Filter Types"
>	CONTAINS	EV (113757, DCM, "X-Ray Filter Material")	1	VNAP	DCID 10006 "X-Ray Filter Materials"
>	CONTAINS	EV (113758, DCM, "X-Ray Filter Thickness Minimum")	1	VNAP	UNITS = EV (mm, UCUM, "mm")
>	CONTAINS	EV (113773, DCM, "X-Ray Filter Thickness Maximum")	1	VNAP	UNITS = EV (mm, UCUM, "mm")
		EV (113790, DCM, "Collimated Field Area")	1	VNAP	UNITS = EV (m2, UCUM, "m2")

Note1: Calculation is pulse width(First Pulse) * number of frames

8.1.5.1.1.7 TID10004 ACCUMULATED FLUOROSCOPY AND PROJECTION X-RAY DOSE DATA

**Table 8.1-46
ACCUMULATED FLUOROSCOPY AND PROJECTION X-RAY DOSE DATA**

NL	Rel with Parent	Concept Name	V M	Presence of Value	Value
		EV (113726, DCM, "Fluoro Dose Area Product Total")	1	ANAP	UNITS = EV (Gy.m2, UCUM, "Gy.m2")
		EV (113728, DCM, "Fluoro Dose (RP) Total")	1	ANAP	UNITS = EV (Gy, UCUM, "Gy")
		EV (113730, DCM, "Total Fluoro Time")	1	ANAP	UNITS = EV (s, UCUM, "s")
		EV (113727, DCM, "Acquisition Dose Area Product Total")	1	ANAP	UNITS = EV (Gy.m2, UCUM, "Gy.m2")
		EV (113729, DCM, "Acquisition Dose (RP) Total")	1	ANAP	UNITS = EV (Gy, UCUM, "Gy")
		EV (113855, DCM, "Total Acquisition Time")	1	ANAP	UNITS = EV (s, UCUM, "s")

8.1.5.1.1.8 TID10007 ACCUMULATED TOTAL PROJECTION RADIOGRAPHY DOSE DATA

**Table 8.1-47
ACCUMULATED TOTAL PROJECTION RADIOGRAPHY DOSE DATA**

NL	Rel with Parent	Concept Name	V M	Presence of Value	Value
		EV (113722, DCM, "Dose Area Product Total")	1	ANAP	UNITS = EV (Gy.m2, UCUM, "Gy.m2")
		EV (113725, DCM, "Dose (RP) Total")	1	ANAP	UNITS = EV (Gy, UCUM, "Gy")
		EV (113731, DCM, "Total Number of Radiographic Frames")	1	ANAP	UNITS = EV (1, UCUM, "no units")
		EV (113780, DCM, "Reference Point Definition")	1	ANAP	

8.2 GRAYSCALE IMAGE CONSISTENCY

Not applicable to this product.

8.3 STANDARD EXTENDED/SPECIALIZED/PRIVATE SOP CLASSES

Not applicable to this product.

8.4 PRIVATE TRANSFER SYNTAXES

Not Applicable to this product.

8.5 DICOM Security Profile Details

8.5.1 Secure Transport Connection Details

The certificate and private key at TLS handshake used by this product may be imported into the local certificate store. It should be formatted in Personal Information Exchange (.pfx).

The certificate and public key for the key validation needs the trusted certificate chain from the root certificate issued by the public certificate authorities (CAs). If the certificate chain is designed by the CA in the local domain, the corresponding DER/PEM encoded X.509 certificates are required to import into the trusted store of this product.

The following table specifies the cipher suites that this product can support in each profile

**Table 8.5-1
SECURE TRANSPORT CONNECTION PROFILES AND CIPHER SUITES**

Profile	Cipher Suite	Default Preference Order(from 1=preferred to n=less preferred)
BCP195 TLS Secure Transport Connection (TLS 1.2)	TLS_ECDHE_ECDSA_WITH_CHACHA20_POLY1305_SHA256	1
	TLS_ECDHE_RSA_WITH_CHACHA20_POLY1305_SHA256	2
	TLS_DHE_RSA_WITH_CHACHA20_POLY1305_SHA256	3
	TLS_ECDHE_RSA_WITH_AES_256_GCM_SHA384	4
	TLS_ECDHE_ECDSA_WITH_AES_256_GCM_SHA384	5
	TLS_ECDHE_RSA_WITH_AES_256_CBC_SHA384	6
	TLS_ECDHE_ECDSA_WITH_AES_256_CBC_SHA384	7
	TLS_DHE_DSS_WITH_AES_256_GCM_SHA384	8
	TLS_DHE_RSA_WITH_AES_256_GCM_SHA384	9
	TLS_DHE_RSA_WITH_AES_256_CBC_SHA256	10
	TLS_DHE_DSS_WITH_AES_256_CBC_SHA256	11
	TLS_DH_anon_WITH_AES_256_GCM_SHA384	12
	TLS_DH_anon_WITH_AES_256_CBC_SHA256	13
	TLS_RSA_WITH_AES_256_GCM_SHA384	14
	TLS_RSA_WITH_AES_256_CBC_SHA256	15
	TLS_ECDHE_RSA_WITH_AES_128_GCM_SHA256	16
	TLS_ECDHE_ECDSA_WITH_AES_128_GCM_SHA256	17
	TLS_ECDHE_RSA_WITH_AES_128_CBC_SHA256	18
	TLS_ECDHE_ECDSA_WITH_AES_128_CBC_SHA256	19
	TLS_DHE_DSS_WITH_AES_128_GCM_SHA256	20
	TLS_DHE_RSA_WITH_AES_128_GCM_SHA256	21
	TLS_DHE_RSA_WITH_AES_128_CBC_SHA256	22
	TLS_DHE_DSS_WITH_AES_128_CBC_SHA256	23
	TLS_RSA_WITH_CAMELLIA_256_CBC_SHA256	24
	TLS_DHE_RSA_WITH_CAMELLIA_256_CBC_SHA256	25
	TLS_DHE_DSS_WITH_CAMELLIA_256_CBC_SHA256	26
	TLS_DHE_RSA_WITH_CAMELLIA_128_CBC_SHA256	27

	TLS_DHE_DSS_WITH_CAMELLIA_128_CBC_SHA256	28
	TLS_DH_anon_WITH_AES_128_GCM_SHA256	29
	TLS_DH_anon_WITH_AES_128_CBC_SHA256	30
	TLS_DH_anon_WITH_CAMELLIA_128_CBC_SHA256	31
	TLS_RSA_WITH_AES_128_GCM_SHA256	32
	TLS_RSA_WITH_AES_128_CBC_SHA256	33
	TLS_RSA_WITH_CAMELLIA_128_CBC_SHA256	34
	TLS_RSA_WITH_NULL_SHA256	35
BCP195 TLS Secure Transport Connection (TLS 1.1/TLS 1.0)	TLS_ECDHE_RSA_WITH_AES_256_CBC_SHA	36
	TLS_ECDHE_ECDSA_WITH_AES_256_CBC_SHA	37
	TLS_DHE_RSA_WITH_CAMELLIA_256_CBC_SHA	38
	TLS_DHE_DSS_WITH_CAMELLIA_256_CBC_SHA	39
	TLS_GOSTR341001_WITH_28147_CNT_IMIT	40
	TLS_GOSTR341094_WITH_NULL_GOSTR3411	41
	TLS_ECDH_anon_WITH_AES_256_CBC_SHA	42
	TLS_DH_anon_WITH_AES_256_CBC_SHA	43
	TLS_DH_anon_WITH_CAMELLIA_256_CBC_SHA	44
	TLS_RSA_WITH_AES_256_CBC_SHA	45
	TLS_DHE_RSA_WITH_AES_256_CBC_SHA	46
	TLS_DHE_DSS_WITH_AES_256_CBC_SHA	47
	TLS_RSA_WITH_CAMELLIA_256_CBC_SHA	48
	TLS_ECDHE_RSA_WITH_AES_128_CBC_SHA	49
	TLS_ECDHE_ECDSA_WITH_AES_128_CBC_SHA	50
	TLS_DHE_RSA_WITH_AES_128_CBC_SHA	51
	TLS_DHE_DSS_WITH_AES_128_CBC_SHA	52
	TLS_DHE_RSA_WITH_CAMELLIA_128_CBC_SHA	53
	TLS_DHE_DSS_WITH_CAMELLIA_128_CBC_SHA	54
	TLS_ECDH_anon_WITH_AES_128_CBC_SHA	55
	TLS_DH_anon_WITH_AES_128_CBC_SHA	56
	TLS_DH_anon_WITH_CAMELLIA_128_CBC_SHA	57
	TLS_RSA_WITH_AES_128_CBC_SHA	58
	TLS_RSA_WITH_CAMELLIA_128_CBC_SHA	59
	TLS_ECDHE_RSA_WITH_RC4_128_SHA	60
	TLS_ECDHE_ECDSA_WITH_RC4_128_SHA	61
	TLS_ECDH_anon_WITH_RC4_128_SHA	62
	TLS_DH_anon_WITH_RC4_128_MD5	63
	TLS_RSA_WITH_RC4_128_SHA	64
	TLS_RSA_WITH_RC4_128_MD5	65
	SSL_CK_RC4_128_WITH_MD5	66
	TLS_ECDHE_RSA_WITH_3DES_EDE_CBC_SHA	67
	TLS_ECDHE_ECDSA_WITH_3DES_EDE_CBC_SHA	68
TLS_DHE_RSA_WITH_3DES_EDE_CBC_SHA	69	
TLS_DHE_DSS_WITH_3DES_EDE_CBC_SHA	70	

	TLS_ECDH_anon_WITH_3DES_EDE_CBC_SHA	71
	TLS_DH_anon_WITH_3DES_EDE_CBC_SHA	72
	TLS_RSA_WITH_3DES_EDE_CBC_SHA	73
	TLS_DHE_RSA_WITH_DES_CBC_SHA	74
	TLS_DHE_DSS_WITH_DES_CBC_SHA	75
	TLS_DH_anon_WITH_DES_CBC_SHA	76
	TLS_RSA_WITH_DES_CBC_SHA	77
	TLS_ECDHE_RSA_WITH_NULL_SHA	78
	TLS_ECDHE_ECDSA_WITH_NULL_SHA	79
	TLS_ECDH_anon_WITH_NULL_SHA	80
	TLS_RSA_WITH_NULL_SHA	81
	TLS_NULL_WITH_NULL_NULL	82
	TLS_RSA_WITH_NULL_MD5	83
Non-Downgrading BCP195 TLS Secure Transport Connection	TLS_ECDHE_ECDSA_WITH_CHACHA20_POLY1305_SHA256	1
	TLS_ECDHE_RSA_WITH_CHACHA20_POLY1305_SHA256	2
	TLS_DHE_RSA_WITH_CHACHA20_POLY1305_SHA256	3
	TLS_ECDHE_RSA_WITH_AES_256_GCM_SHA384	4
	TLS_ECDHE_ECDSA_WITH_AES_256_GCM_SHA384	5
	TLS_ECDHE_RSA_WITH_AES_256_CBC_SHA384	6
	TLS_ECDHE_ECDSA_WITH_AES_256_CBC_SHA384	7
	TLS_DHE_DSS_WITH_AES_256_GCM_SHA384	8
	TLS_DHE_RSA_WITH_AES_256_GCM_SHA384	9
	TLS_DHE_RSA_WITH_AES_256_CBC_SHA256	10
	TLS_DHE_DSS_WITH_AES_256_CBC_SHA256	11
	TLS_DH_anon_WITH_AES_256_GCM_SHA384	12
	TLS_DH_anon_WITH_AES_256_CBC_SHA256	13
	TLS_RSA_WITH_AES_256_GCM_SHA384	14
	TLS_RSA_WITH_AES_256_CBC_SHA256	15
	TLS_ECDHE_RSA_WITH_AES_128_GCM_SHA256	16
	TLS_ECDHE_ECDSA_WITH_AES_128_GCM_SHA256	17
	TLS_ECDHE_RSA_WITH_AES_128_CBC_SHA256	18
	TLS_ECDHE_ECDSA_WITH_AES_128_CBC_SHA256	19
	TLS_DHE_DSS_WITH_AES_128_GCM_SHA256	20
	TLS_DHE_RSA_WITH_AES_128_GCM_SHA256	21
	TLS_DHE_RSA_WITH_AES_128_CBC_SHA256	22
	TLS_DHE_DSS_WITH_AES_128_CBC_SHA256	23
	TLS_RSA_WITH_CAMELLIA_256_CBC_SHA256	24
	TLS_DHE_RSA_WITH_CAMELLIA_256_CBC_SHA256	25
	TLS_DHE_DSS_WITH_CAMELLIA_256_CBC_SHA256	26
	TLS_DHE_RSA_WITH_CAMELLIA_128_CBC_SHA256	27
	TLS_DHE_DSS_WITH_CAMELLIA_128_CBC_SHA256	28
	TLS_DH_anon_WITH_AES_128_GCM_SHA256	29
	TLS_DH_anon_WITH_AES_128_CBC_SHA256	30

	TLS_DH_anon_WITH_CAMELLIA_128_CBC_SHA256	31
	TLS_RSA_WITH_AES_128_GCM_SHA256	32
	TLS_RSA_WITH_AES_128_CBC_SHA256	33
	TLS_RSA_WITH_CAMELLIA_128_CBC_SHA256	34
	TLS_RSA_WITH_NULL_SHA256	35
Extended BCP195 TLS Profile Secure Transport Connection	TLS_ECDHE_RSA_WITH_AES_256_GCM_SHA384	4
	TLS_ECDHE_ECDSA_WITH_AES_256_GCM_SHA384	5
	TLS_DHE_RSA_WITH_AES_256_GCM_SHA384	9
	TLS_ECDHE_RSA_WITH_AES_128_GCM_SHA256	16
	TLS_ECDHE_ECDSA_WITH_AES_128_GCM_SHA256	17
	TLS_DHE_RSA_WITH_AES_128_GCM_SHA256	21