

**DICOM CONFORMANCE STATEMENT**

**STORAGE SCU**

**STORAGE COMMITMENT SCU**

**MODALITY WORKLIST MANAGEMENT SCU**

**MODALITY PERFORMED PROCEDURE STEP SCU**

**GRAYSCALE PRINT SCU**

**QUERY/RETRIEVE SCU**

**STORAGE SCP**

**AND**

**MEDIA STORAGE**

**FOR**

**TOSHIBA DIGITAL RADIOGRAPHY SYSTEM**

**MODEL DFP-8000D**

**(MIIXR0010EAA)**

**TOSHIBA CORPORATION**

**IMPORTANT !**

- (1) No part of this manual may be copied or reprinted, in whole or in part, without written permission.
- (2) The contents of this manual are subject to change without prior notice and without our legal obligation.

## Table of Contents

<b>1. INTRODUCTION.....</b>	<b>1</b>
1.1. REFERENCES .....	1
1.2. DEFINITIONS .....	1
1.3. ACRONYMS, ABBREVIATIONS AND SYMBOLS .....	2
<b>2. IMPLEMENTATION MODELS.....</b>	<b>3</b>
2.1. STORAGE AE .....	3
2.1.1. Application Data Flow Diagram.....	3
2.1.2. Functional Definitions of AE's.....	3
2.1.3. Sequencing of Real World Activities .....	3
2.2. STORAGE COMMITMENT AE.....	5
2.2.1. Application Data Flow Diagram.....	5
2.2.2. Functional Definitions of AE's.....	5
2.2.3. Sequencing of Real World Activities .....	5
2.3. MODALITY WORKLIST AE .....	6
2.3.1. Application Data Flow Diagram.....	6
2.3.2. Functional Definitions of AE's.....	6
2.3.3. Sequencing of Real World Activities .....	6
2.4. MODALITY PERFORMED PROCEDURE STEP AE.....	7
2.4.1. Application Data Flow Diagram.....	7
2.4.2. Functional Definitions of AE's.....	7
2.4.3. Sequencing of Real World Activities .....	7
2.5. PRINT AE .....	9
2.5.1. Application Data Flow Diagram.....	9
2.5.2. Functional Definitions of AE's.....	9
2.5.3. Sequencing of Real World Activities .....	9
2.6. QUERY/RETRIEVE AE.....	11
2.6.1. Application Data Flow Diagram.....	11
2.6.2. Functional Definitions of AE's.....	11
2.6.3. Sequencing of Real World Activities .....	11
2.7. STORAGE SCP AE.....	13
2.7.1. Application Data Flow Diagram.....	13
2.7.2. Functional Definitions of AE's.....	13
2.7.3. Sequencing of Real World Activities .....	13
2.8. DICOM RECORDING AE .....	14
2.8.1. Application Data Flow Diagram.....	14
2.8.2. Functional Definitions of AE's.....	14
2.8.3. Sequencing of Real World Activities .....	14
2.9. DICOM READER AE.....	16
2.9.1. Application Data Flow Diagram.....	16
2.9.2. Functional Definitions of AE's.....	16
2.9.3. Sequencing of Real World Activities .....	16
<b>3. AE SPECIFICATIONS .....</b>	<b>18</b>
3.1. STORAGE AE SPECIFICATION.....	18
3.1.1. Association Establishment Policies.....	18
3.1.2. Association Initiation by Real-World Activity.....	18
3.2. STORAGE COMMITMENT AE SPECIFICATION .....	20
3.2.1. Association Establishment Policies.....	20
3.2.2. Association Initiation by Real-World Activity.....	20
3.2.3. Association Acceptance Policy .....	21

3.3.	MODALITY WORKLIST AE SPECIFICATION .....	23
3.3.1.	Association Establishment Policies.....	23
3.3.2.	Association Initiation by Real-World Activity.....	23
3.4.	MODALITY PERFORMED PROCEDURE STEP AE SPECIFICATION .....	25
3.4.1.	Association Establishment Policies.....	25
3.4.2.	Association Initiation by Real-World Activity.....	25
3.5.	PRINT AE SPECIFICATION.....	27
3.5.1.	Association Establishment Policies.....	27
3.5.2.	Association Initiation by Real-World Activity.....	28
3.6.	QUERY/RETRIEVE AE SPECIFICATION .....	30
3.6.1.	Association Establishment Policies.....	30
3.6.2.	Association Initiation by Real-World Activity.....	30
3.7.	STORAGE SCP SPECIFICATION.....	32
3.7.1.	Association Establishment Policies.....	32
3.7.2.	Association Initiation by Real-World Activity.....	33
3.7.3.	Association Acceptance Policy .....	33
3.8.	DICOM RECORDING SPECIFICATION.....	34
3.8.1.	File Meta Information for the Application Entity.....	34
3.8.2.	Real-World Activity .....	34
3.8.3.	Media Storage Application Profile .....	34
3.8.4.	Information Object Definition and DICOMDIR keys .....	34
3.9.	DICOM READER SPECIFICATION.....	35
3.9.1.	File Meta Information for the Application Entity.....	35
3.9.2.	Real-World Activity .....	35
3.9.3.	Media Storage Application Profile .....	35
3.9.4.	Information Object Definition and DICOMDIR keys .....	35
<b>4.</b>	<b>AUGMENTED AND PRIVATE APPLICATION PROFILES.....</b>	<b>36</b>
4.1.	AUGMENTED APPLICATION PROFILES.....	36
4.1.1.	AUG-XABC-CD.....	36
4.2.	PRIVATE APPLICATION PROFILES.....	36
<b>5.</b>	<b>COMMUNICATION PROFILES.....</b>	<b>37</b>
5.1.	SUPPORTED COMMUNICATION STACKS .....	37
5.2.	OSI STACK .....	37
5.3.	TCP/IP STACK .....	37
5.4.	API.....	37
5.4.1.	Physical Media Support .....	37
5.5.	POINT-TO-POINT STACK .....	37
<b>6.</b>	<b>EXTENSIONS/SPECIALIZATIONS/PRIVATIZATIONS .....</b>	<b>38</b>
<b>7.</b>	<b>CONFIGURATION.....</b>	<b>39</b>
7.1.	AE TITLE/PRESENTATION ADDRESS MAPPING .....	39
7.2.	IMPLEMENTATION INFORMATION AND MAXIMUM RECEPTION PDU SIZE .....	39
<b>8.</b>	<b>SUPPORT OF EXTENDED CHARACTER SETS.....</b>	<b>40</b>
<b>9.</b>	<b>X-RAY ANGIOGRAPHIC INFORMATION OBJECT DEFINITION .....</b>	<b>41</b>
9.1.	ENTITY MODULE DEFINITIONS .....	41
9.1.1.	Media Storage Directory IOD Modules.....	41
9.1.2.	Media Storage XA IOD Modules .....	41
9.1.3.	XA IOD Modules.....	42
9.2.	DICOM FILE META INFORMATION.....	43

9.2.1.	DICOM File Meta Information of Directory IOD .....	43
9.2.2.	DICOM File Meta Information of XA IOD .....	43
9.3.	BASIC DIRECTORY INFORMATION OBJECT DEFINITIONS .....	43
9.3.1.	File-set Identification Module .....	43
9.3.2.	Directory Information Module .....	44
9.4.	DEFINITION OF SPECIFIC DIRECTORY RECORDS .....	44
9.4.1.	PATIENT keys.....	44
9.4.2.	STUDY keys.....	44
9.4.3.	SERIES keys.....	45
9.4.4.	IMAGE keys.....	45
9.5.	XA INFORMATION OBJECT DEFINITIONS .....	47
9.5.1.	Patient Module .....	47
9.5.2.	General Study Module .....	47
9.5.3.	Patient Study Module .....	47
9.5.4.	General Series Module .....	48
9.5.5.	General Equipment Module.....	48
9.5.6.	General Image Module.....	48
9.5.7.	Image Pixel Module.....	49
9.5.8.	Contrast/Bolus Module.....	49
9.5.9.	Cine Module.....	50
9.5.10.	Multi-frame Module.....	50
9.5.11.	Frame Pointers Module .....	50
9.5.12.	Mask Module.....	50
9.5.13.	Display Shutter Module .....	51
9.5.14.	Device Module .....	51
9.5.15.	Therapy Module .....	51
9.5.16.	X-ray Image Module .....	52
9.5.17.	X-ray Acquisition Module.....	52
9.5.18.	X-ray Collimator Module.....	53
9.5.19.	X-ray Table Module .....	53
9.5.20.	XA Positioner Module.....	53
9.5.21.	Overlay Plane Module .....	54
9.5.22.	Multi-Frame Overlay Module .....	54
9.5.23.	Curve Module.....	54
9.5.24.	VOI LUT Module .....	55
9.5.25.	SOP Common Module.....	55
<b>10.</b>	<b>MODALITY WORKLIST MANAGEMENT INFORMATION OBJECT DEFINITION.....</b>	<b>56</b>
10.1.	MATCHING KEY ATTRIBUTES .....	56
10.1.1.	Scheduled Procedure Step Module .....	56
10.2.	RETURN KEY ATTRIBUTES.....	56
10.2.1.	SOP Common Module.....	56
10.2.2.	Scheduled Procedure Step Module .....	56
10.2.3.	Requested Procedure Module.....	57
10.2.4.	Imaging Service Request Module .....	57
10.2.5.	Visit Identification Module .....	58
10.2.6.	Visit Status Module .....	58
10.2.7.	Visit Relationship Module.....	58
10.2.8.	Visit Admission Module.....	59
10.2.9.	Patient Identification Module .....	59
10.2.10.	Patient Demographic Module .....	59
10.2.11.	Patient Medical Module .....	59
<b>11.</b>	<b>MODALITY PERFORMED PROCEDURE STEP INFORMATION OBJECT DEFINITION.....</b>	<b>61</b>

11.1.	MODALITY PERFORMED PROCEDURE STEP IOD MODULES .....	61
11.1.1.	N-CREATE.....	61
11.1.2.	N-SET.....	61
11.2.	N-CREATE ATTRIBUTES .....	62
11.2.1.	SOP Common Module.....	62
11.2.2.	Performed Procedure Step Relationship Module.....	62
11.2.3.	Performed Procedure Step Information Module.....	63
11.2.4.	Image Acquisition Results Module .....	63
11.3.	N-SET ATTRIBUTES .....	64
11.3.1.	Performed Procedure Step Information Module.....	64
11.3.2.	Image Acquisition Results Module .....	64
11.3.3.	Radiation Dose Module.....	65
11.3.4.	Billing and Material Management Codes Module.....	65
<b>12.</b>	<b>DIMSE-SERVICE AND ATTRIBUTES.....</b>	<b>67</b>
12.1.	DIMSE-SERVICES .....	67
12.2.	BASIC FILM SESSION SOP CLASS.....	68
12.2.1.	N-CREATE Attributes.....	68
12.2.2.	N-DELETE Attributes.....	68
12.3.	BASIC FILM BOX SOP CLASS.....	68
12.3.1.	N-CREATE Attributes.....	68
12.3.2.	N-DELETE Attributes.....	69
12.4.	BASIC GRAYSCALE IMAGE BOX SOP CLASS .....	69
12.4.1.	N-SET Attributes.....	69
12.5.	PRINTER SOP CLASS .....	69
12.5.1.	N-EVENT-REPORT.....	69
12.5.2.	N-GET Attributes .....	69
12.6.	PRINT JOB SOP CLASS .....	70
12.6.1.	N-EVENT-REPORT.....	70
<b>13.</b>	<b>QUERY ATTRIBUTES.....</b>	<b>71</b>
13.1.	PATIENT ROOT INFORMATION MODEL.....	71
13.2.	STUDY ROOT INFORMATION MODEL.....	72

## 1. Introduction

This document is a DICOM Conformance Statement for Toshiba's Digital Radiography Systems. It is intended to provide the reader with the knowledge of how to integrate this product within a DICOM compliant hospital network. It details the DICOM Service Classes, Information Objects, and Communication Protocols which are supported by this product.

If the readers are unfamiliar with DICOM, it is recommended that they read the DICOM Specification(referenced below) prior to reading this conformance statement. Also note that this document is formatted according to the DICOM Specification, Part 2:Conformance.

### 1.1. References

- ACR-NEMA Digital Imaging and Communications in Medicine, DICOM V3.0.

### 1.2. Definitions

- **Association Establishment** - An Association Establishment is the first phase of communication between two DICOM Application Entities. The AEs use the Association Establishment to negotiate how data will be encoded and the type of data to be exchanged.
- **Called Application Entity Title** - The Called AE Title defines the intended receiver of an Association.
- **Calling Application Entity Title** - The Calling AE Title defines the requestor of an Association.
- **DICOM Message Service Element (DIMSE)** - A DIMSE defines the services and protocols utilized by an Application Entity to exchange messages.
- **Information Object Definition (IOD)** - An IOD is a data model which is an abstraction of real-world information. This data model defines the nature and attributes relevant to the class of real-world objects represented.
- **Service Class Provider (SCP)** - A Service Class Provider plays the "server" role to perform operations and invoke notifications during an Association. An example of a Storage Service Class Provider would be an image storage device. In this case, the image storage device is storing the image that was sent by a Service Class User.
- **Service Class User (SCU)** - A Service Class User plays the "client" role to invoke operations and perform notifications during an Association. An example of a Storage Service Class User would be an image acquisition device. In this case, the image acquisition device will create and send a DICOM image by requesting that a Service Class Provider store that image.
- **Service/Object Pair (SOP) Class** - A SOP Class is defined by the union of an Information Object Definition and a set of DIMSE Services. A DICOM Application Entity may support one or more SOP Classes. Each SOP Class is uniquely identified by a SOP Class UID.
- **SOP Instance** - A specific occurrence of an Information Object.
- **Transfer Syntax** - The Transfer Syntax is a set of encoding rules that allow DICOM Application Entities to negotiate the encoding techniques (e.g. data element structure, byte ordering, compression) they are able to support. The Transfer Syntax is negotiated during Association Negotiation.
- **Unique Identifier (UID)** - A Unique Identifier is a globally unique, ISO compliant, ASCII-numeric string. It guarantees uniqueness across multiple countries, sites, vendors and equipment.

### 1.3. Acronyms, Abbreviations and Symbols

- ACC American College of Cardiology
- ACR American College of Radiology
- AE Application Entity
- ANSI American National Standards Institute
- ASCII American Standard Code for Information Interchange
- CEN TC251 Comite Europeen de Normalisation - Technical Committee 251 - Medical Informatics
- DICOM Digital Imaging and Communications in Medicine
- DIMSE DICOM Message Service Element
- DIMSE-C DICOM Message Service Element - Composite
- DIMSE-N DICOM Message Service Element – Normalized
- FSC File-set Creator
- FSR File-set Reader
- HIS Hospital Information System
- HL7 Health Level 7
- IE Information Entity
- IOD Information Object Definition
- ISO International Standards Organization
- JIRA Japan Industries Association of Radiological Systems
- MPPS Modality Performed Procedure Step
- NEMA National Electrical Manufacturers Association
- OSI Open Systems Interconnection
- PDU Protocol Data Unit
- RIS Radiology Information System
- SCP Service Class Provider
- SCU Service Class User
- TCP/IP Transmission Control Protocol/Internet Protocol
- UID Unique Identifier



## 2. Implementation Models

### 2.1. Storage AE

#### 2.1.1. Application Data Flow Diagram

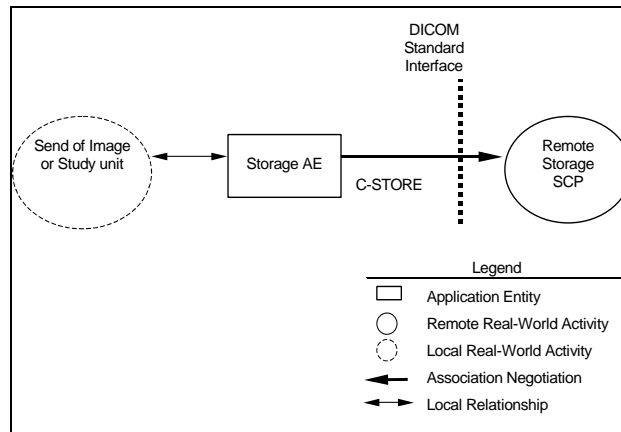

**Figure 2-1 Data Flow Diagram for Storage**

### 2.1.2. Functional Definitions of AE's

#### 2.1.2.1. Send of image or Study unit

Storage AE is used to transmit images to a remote DICOM device. It therefore performs the following tasks:

- Builds DICOM XA Information Objects
- Establishes DICOM Association with a remote DICOM device
- Performs storage of DICOM XA Information Objects to a remote DICOM device

### 2.1.3. Sequencing of Real World Activities

#### 2.1.3.1. Features

##### 2.1.3.1.1. Send of image or Study unit

- Operator requests to send images after selecting the images from the Patient List or from the Study List or from the Image List.
- It is able to automatically send images after acquisition or after finishing the study if it is configured.
- When the transfer fails, Operator can manually attempt to resend the image at a later time.

#### 2.1.3.2. Operation

##### 2.1.3.2.1. Send of image or Study unit

The operation for manual image transferring is described below:

- Step-1: Select the images, the study or the patient to be transferred.
- Step-2: Select the destination of image transfer.
- Step-3: Request transfer.

Regarding automatic send operation it is skipped over all Steps.

## 2.2. Storage Commitment AE

### 2.2.1. Application Data Flow Diagram

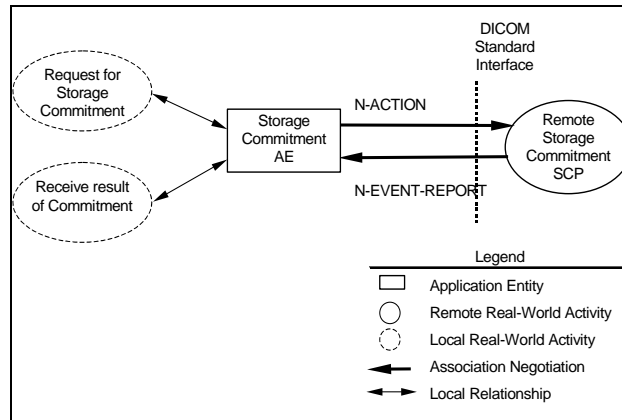

**Figure 2-2 Data Flow Diagram for Storage Commitment**

## 2.2.2. Functional Definitions of AE's

### 2.2.2.1. Request for Storage Commitment

Storage Commitment AE is used to transmit images and request for Storage Commitment to a remote DICOM device. It therefore performs the following tasks:

- Requests DICOM Storage Commitment to a remote DICOM device

### 2.2.2.2. Receive result of Commitment

Storage Commitment AE is used to receive response of Storage Commitment from a remote DICOM device.

## 2.2.3. Sequencing of Real World Activities

### 2.2.3.1. Features

#### 2.2.3.1.1. Request for Storage Commitment

- Storage Commitment request is automatically sent after sending images.

#### 2.2.3.1.2. Receive result of Commitment

- Storage Commitment response is received automatically.

### 2.2.3.2. Operation

#### 2.2.3.2.1. Request for Storage Commitment

There is no specific operation for request for the storage commitment.

#### 2.2.3.2.2. Receive result of Commitment

There is no specific operation for Receive result of Commitment.

## 2.3. Modality Worklist AE

### 2.3.1. Application Data Flow Diagram

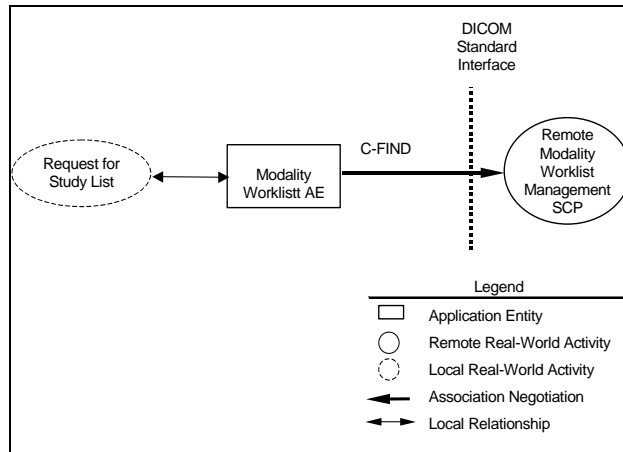

Figure 2-3 Data Flow Diagram for Modality Worklist

### 2.3.2. Functional Definitions of AE's

#### 2.3.2.1. Request for Study List

Modality Worklist AE is used to transmit request for Study List to a remote DICOM device and to retrieve Study List with Procedure Step. It therefore performs the following tasks:

- Establishes DICOM Association with a remote DICOM device
- Performs request of DICOM Modality Worklist Objects to a remote DICOM device
- Retrieves Study List with Procedure Step Information from a remote DICOM device

### 2.3.3. Sequencing of Real World Activities

#### 2.3.3.1. Features

##### 2.3.3.1.1. Request for Study List

- Operator requests to transmit requesting Study List and retrieves it with Procedure Step.
- The requesting Study List is sent and retrieves with Procedure Step automatically.

#### 2.3.3.2. Operation

##### 2.3.3.2.1. Request for Study List

The operation for Request for Study List is described below:

Step-1: Specify the Scheduled Procedure Step Start Date, Scheduled Performing Physician's Name, Patient ID, etc, request for Study List to the remote SCP.

Step-2: Select one of the Study List for the examination.

Step-3: Register the patient name, patient ID, etc. to the Digital Radiography System.

## 2.4. Modality Performed Procedure Step AE

### 2.4.1. Application Data Flow Diagram

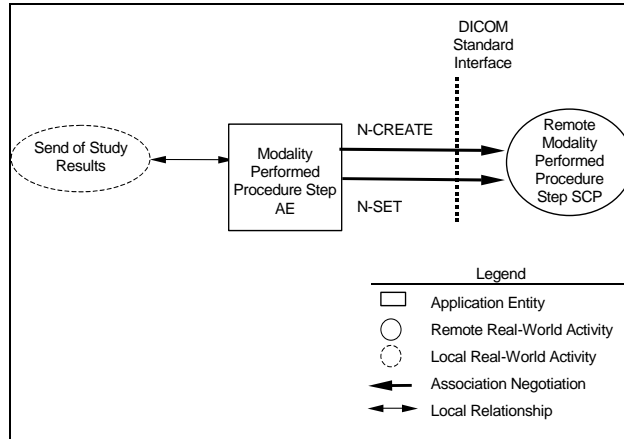

**Figure 2-4 Data Flow Diagram for Modality Performed Procedure Step**

## 2.4.2. Functional Definitions of AE's

### 2.4.2.1. Send of Study Results

Modality Performed Procedure Step AE is used to transmit the information of Modality Performed Procedure Step to a remote DICOM device. It therefore performs the following tasks:

- Builds DICOM Modality Performed Procedure Step Objects
- Establishes DICOM Association with a remote DICOM device
- Performs transmit of DICOM Modality Performed Procedure Step Objects to a remote DICOM device

## 2.4.3. Sequencing of Real World Activities

### 2.4.3.1. Features

#### 2.4.3.1.1. Send of Study Results

- The start of study is sent automatically when operator invoked the study start.
- The study results are sent automatically when operator invoked the study finish.
- Operator requests to transmit the start of study or the study results after operator invoke examination finish.

## **2.4.3.2. Operation**

### **2.4.3.2.1. Send of Study Results**

The operation for send of study results is described below:

Step-1: Press “Finish Study” button when the study finished completely.

Step-2: Input the performed procedure step information for example action items, dose items or billing items.

Step-3: Press “Completed” button to send study results.

## 2.5. Print AE

### 2.5.1. Application Data Flow Diagram

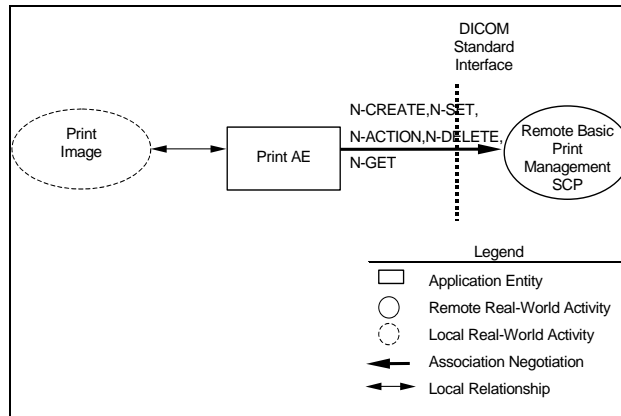

**Figure 2-5 Data Flow Diagram for Print**

### 2.5.2. Functional Definitions of AE's

#### 2.5.2.1. Print image

Print AE is used to transmit request for Print images to a remote DICOM device. It therefore performs the following tasks:

- Builds DICOM Basic Grayscale Print Objects
- Establishes DICOM Association with a remote DICOM device
- Performs transmit of DICOM Basic Grayscale Print Objects to a remote DICOM device

### 2.5.3. Sequencing of Real World Activities

#### 2.5.3.1. Features

##### 2.5.3.1.1. Print image

- The number of frames in the rows and columns on each film can be specified as desired, up to a total maximum of 35 frames per film.
- If an error occurs during printing, a request to retry printing is issued manually.
- Operator requests to print out images after selecting the transferred images from the patient, study or series list or mini-image screen.
- Print requests are placed on a queue, and are executed in the background.

## **2.5.3.2. Operation**

### **2.5.3.2.1. Print Image**

The operation for manual print images is described below:

Step-1: Select the images, series, studies or the patient to be printed.

Step-2: Select the destination of print images and request print out.



## 2.6. Query/Retrieve AE

### 2.6.1. Application Data Flow Diagram

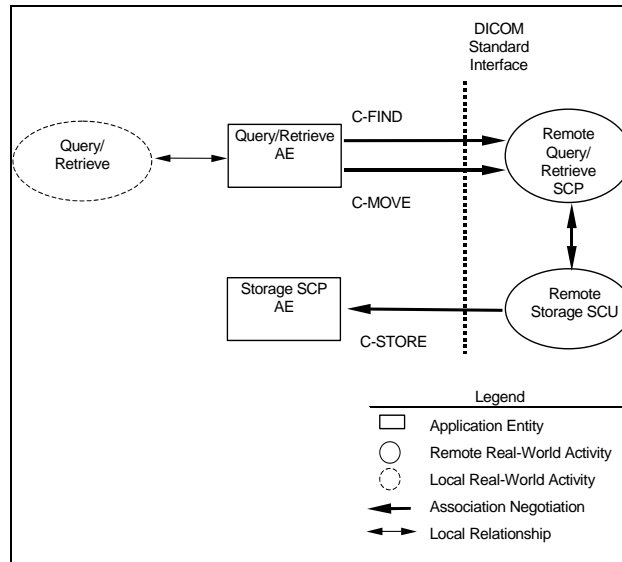

Figure 2-6 Data Flow Diagram for Query/Retrieve

## 2.6.2. Functional Definitions of AE's

### 2.6.2.1. Query/Retrieve

Q/R AE is used to transmit Request for Patient/Study List to a remote DICOM device and to retrieve the requested images to the retrieve device. It therefore performs the following tasks:

- Establishes DICOM Association with a remote DICOM device
- Performs request of DICOM Query Objects to a remote DICOM device
- Performs request of DICOM Retrieve Objects to a remote DICOM device after getting the result of the searching request
- Retrieves the requested images from a remote DICOM device

## 2.6.3. Sequencing of Real World Activities

### 2.6.3.1. Features

#### 2.6.3.1.1. Query/Retrieve

- Operator requests to transmit requesting Patient/Study List and retrieves the requested images from a remote DICOM device.

### 2.6.3.2. Operation

#### 2.6.3.2.1. Query/Retrieve

The operation for Query/Retrieve is described below:

Step-1: Specify Patient Name, etc, request for Patient/Study List to the remote SCP.

Step-2: Select the images, the studies or patients to be sent.

Step-3: Retrieve the requested images from a remote DICOM device and stores the received images to the Digital Radiography System.

## 2.7. Storage SCP AE

### 2.7.1. Application Data Flow Diagram

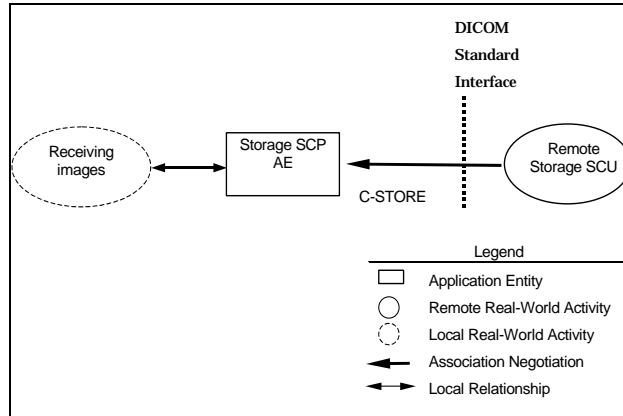

**Figure 2-7 Data Flow Diagram for Storage SCP**

### 2.7.2. Functional Definitions of AE's

#### 2.7.2.1. Receiving images

Storage SCP AE is used to receive DICOM XA Information Objects.

### 2.7.3. Sequencing of Real World Activities

#### 2.7.3.1. Features

##### 2.7.3.1.1. Receiving images

- Storage SCP AE receives XA images from a remote DICOM device.
- Storage SCP AE archives the received images to local system.

#### 2.7.3.2. Operation

##### 2.7.3.2.1. Receiving images

There is no specific operation.

## 2.8. DICOM Recording AE

### 2.8.1. Application Data Flow Diagram

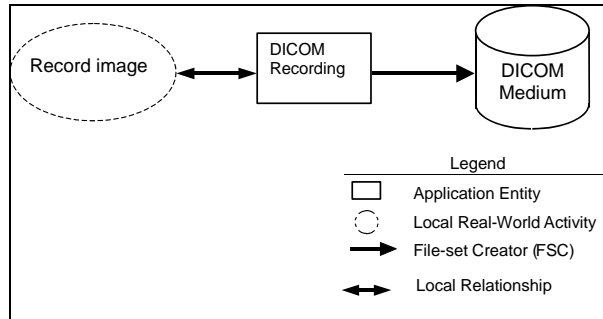

**Figure 2-8 Data Flow Diagram for DICOM Recording**

### 2.8.2. Functional Definitions of AE's

The DICOM Recording supports the following tasks:

- Builds DICOM XA Information Objects.
- Creates a DICOMDIR file that represents the contents of DICOM XA Information Objects to be recorded.
- Records DICOM XA Information Objects and DICOMDIR from the local storage to the DICOM media (CD-R media or DVD-RAM media).
- Duplicates the File-set of the local storage onto the blank DICOM media.

### 2.8.3. Sequencing of Real World Activities

#### 2.8.3.1. Features

##### 2.8.3.1.1. Record image

- Operator requests to transfer images to the local storage after selecting the transferred images from the Patient List or from the Image List.
- Operator requests to record the images of the local storage onto the DICOM media after transferring all data that are to be recorded.
- When the size of an image exceeds the capacity of the DICOM media, the request of transferring an image is canceled.
- Each DICOM media has a DICOMDIR file that represents the contents of the data as recorded.
- Operator can request to duplicate the DICOM media from the recorded DICOM media to the blank DICOM media
- Record requests are placed on a queue, and are executed in the background.

#### 2.8.3.2. Operation

##### 2.8.3.2.1. Record image

The operation for manual transfer of X-ray examination is described below:

Step-1: Select the images, the study or the patient to be transferred.

Step-2: Insert a blank DICOM media.

Step-3: Request recording the transferred images onto the DICOM media.

Regarding automatic record operation it is skipped over STEP-1 and STEP-2.

## 2.9. DICOM Reader AE

### 2.9.1. Application Data Flow Diagram

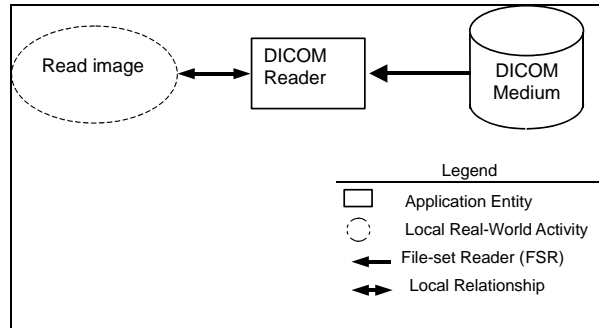

**Figure 2-9 Data Flow Diagram for DICOM Reader**

### 2.9.2. Functional Definitions of AE's

The DICOM Reader supports the following tasks:

- Reads the DICOMDIR file that represents the contents of the data as recorded.
- Displays the ordered list of patient and image identifying information or icon images.
- Reads the File-set of the DICOM media (CD-R media or DVD-RAM media) and writes it onto the local storage of the DICOM Reader.

### 2.9.3. Sequencing of Real World Activities

#### 2.9.3.1. Features

##### 2.9.3.1.1. Read image

- Operator inserts the DICOM media to be read.
- Operator requests to display the list of images or the catalog of icon images that are recorded on the DICOM media.
- Operator selects images from the list or from the icon images and requests to review the image from the DICOM media.
- Operator can request to read images from the DICOM media onto the local storage and then operator can request to review the image from the local storage.
- Operator can request to delete the images on the local storage.
- The images on the local storage remain after being recorded onto the DICOM media, so operators can display these images from the local storage also.
- Read requests are placed on a queue, and are executed in the background.

#### 2.9.3.2. Operation

##### 2.9.3.2.1. Read image

The operation for manual review of X-ray examination is described below:

Step-1: Insert the DICOM media to be review.

Step-2: Select one image from the list or from the thumbnail images.

Step-3: Request to read images from the DICOM media onto the local storage and then operator can request to review the image from the local storage.

Step-4: Request forward play, backward play, step by step, or other image processing.

### 3. AE Specifications

#### 3.1. Storage AE Specification

Storage AE provides Standard Conformance to the following DICOM SOP Classes as an SCU:

*Table 3-1*

SOP Class Name	SOP Class UID
XA Image Storage	1.2.840.10008.5.1.4.1.1.12.1

#### 3.1.1. Association Establishment Policies

##### 3.1.1.1. General

AE will utilize and understand the following Application Context Name:

*Table 3-2*

DICOM V3.0 Application Context	1.2.840.10008.3.1.1.1
--------------------------------	-----------------------

AE supports a minimum PDU size of 4Kbytes and a maximum PDU size of 32Kbytes.

The default value is set to 28Kbytes.

##### 3.1.1.2. Number of Associations

AE can only establish one association at a time, independent of the number of destinations chosen.

##### 3.1.1.3. Asynchronous Nature

AE allows a single outstanding operation on any association. Therefore, AE does not support asynchronous operations window negotiation, other than the default as specified by the DICOM specification.

##### 3.1.1.4. Implementation Identifying Information

AE will specify the following Implementation Identifying Information:

- Implementation Class UID                   1.2.392.200036.9116.7.8.12.10.31.1.1
- Implementation Version Name            TM\_INFINIX\_V1.0

#### 3.1.2. Association Initiation by Real-World Activity

AE initiates an association when the following activity is chosen by the operator.

- "Send of Image or Patient unit"
  - ◆ Storage                   - Create and store an XA image to a remote DICOM device

##### 3.1.2.1. Real-World Activity - Storage

##### 3.1.2.1.1. Associated Real-World Activity - Storage



Storage is executed by the Digital Radiography System after the operator requests the image transfer.

### 3.1.2.1.2. Proposed Presentation Contexts - Storage

AE will propose Presentation Contexts as shown in the following table:

**Table 3-3**

Presentation Context Table					
Abstract Syntax		Transfer Syntax		Role	Extended Negotiation
Name	UID	Name List	UID List		
XA Image Storage	1.2.840.10008.5.1.4.1.1.12 .1	Implicit VR Little Endian	1.2.840.10008.1.2	SCU	None
XA Image Storage	1.2.840.10008.5.1.4.1.1.12 .1	Explicit VR Little Endian	1.2.840.10008.1.2. 1	SCU	None
XA Image Storage	1.2.840.10008.5.1.4.1.1.12 .1	*1	1.2.840.10008.1.2. 4.70	SCU	None

\*1:JPEG Lossless (Process 14 [Selection Value1])

#### 3.1.2.1.2.1. SOP Specific Conformance - Storage

- Attributes are described in Chapter 9.

### 3.2. Storage Commitment AE Specification

Storage Commitment AE provides Standard Conformance to the following DICOM SOP Classes as an SCU:

**Table 3-4**

SOP Class Name	SOP Class UID
Storage Commitment Push Model	1.2.840.10008.1.20.1

#### 3.2.1. Association Establishment Policies

##### 3.2.1.1. General

AE will utilize and understand the following Application Context Name:

**Table 3-5**

DICOM V3.0 Application Context	1.2.840.10008.3.1.1.1
--------------------------------	-----------------------

AE supports a minimum PDU size of 4Kbytes and a maximum PDU size of 32Kbytes.

The default value is set to 28Kbytes.

##### 3.2.1.2. Number of Associations

AE can only establish one association at a time, independent of the number of destinations chosen.

##### 3.2.1.3. Asynchronous Nature

AE allows a single outstanding operation on any association. Therefore, AE does not support asynchronous operations window negotiation, other than the default as specified by the DICOM specification.

##### 3.2.1.4. Implementation Identifying Information

AE will specify the following Implementation Identifying Information:

- Implementation Class UID                   1.2.392.200036.9116.7.8.12.10.31.1.1
- Implementation Version Name            TM\_INFINIX\_V1.0

#### 3.2.2. Association Initiation by Real-World Activity

AE initiates an association when the following activity is chosen by the operator.

- "Request for Storage Commitment"
  - ◆ Request Storage Commitment - Request commitment of stored XA images to a remote DICOM device

##### 3.2.2.1. Real-World Activity – Request Storage Commitment

###### 3.2.2.1.1. Associated Real-World Activity – Request Storage Commitment

Storage Commitment is executed by the Digital Radiography System after the operator's image transfer requests were finished.

### 3.2.2.1.2. Proposed Presentation Contexts – Request Storage Commitment

AE will propose Presentation Contexts as shown in the following table:

**Table 3-6**

Presentation Context Table					
Abstract Syntax		Transfer Syntax		Role	Extended Negotiation
Name	UID	Name List	UID List		
Storage Commitment Push Model	1.2.840.10008.1.20.1	Implicit VR Little Endian	1.2.840.10008.1.2	SCU	None
Storage Commitment Push Model	1.2.840.10008.1.20.1	Explicit VR Little Endian	1.2.840.10008.1.2.1	SCU	None

#### 3.2.2.1.2.1. SOP Specific Conformance – Request Storage Commitment

- The Application conforms to the definition of Storage Commitment SCU in accordance with the DICOM Standard.
- AE can receive an N-EVENT-REPORT on the separated Association on which the N-ACTION operation was performed. See 3.2.3.1

### 3.2.3. Association Acceptance Policy

AE accepts an association generated by remote applications.

"Receive result of Storage Commitment"

- Receive Storage Commitment - Receive a result of Commitments from a remote DICOM device

#### 3.2.3.1. Real-World Activity – Receive Storage Commitment

##### 3.2.3.1.1. Associated Real-World Activity – Receive Storage Commitment

When a result of commitments is sent by a remote system, an association is accepted.

#### 3.2.3.1.2. Presentation Context Table – Receive Storage Commitment

AE accepts the following Presentation Contexts shown below:

**Table 3-7**

Presentation Context Table					
Abstract Syntax		Transfer Syntax		Role	Extended Negotiation
Name	UID	Name List	UID List		
Storage Commitment Push Model	1.2.840.10008.1.20.1	Implicit VR Little Endian	1.2.840.10008.1.2	SCU	None
Storage Commitment Push Model	1.2.840.10008.1.20.1	Explicit VR Little Endian	1.2.840.10008.1.2.1	SCU	None

**3.2.3.1.2.1. SOP Specific Conformance – Receive Storage Commitment**

- The Application conforms to the definition of Storage Commitment SCU in accordance with the DICOM Standard.
- AE can receive an N-EVENT-REPORT on the separated Association on which the N-ACTION operation was performed.

### 3.3. Modality Worklist AE Specification

Modality Worklist AE provides Standard Conformance to the following DICOM SOP Classes as an SCU:

**Table 3-8**

SOP Class Name	SOP Class UID
Modality Worklist Information Model-FIND	1.2.840.10008.5.1.4.31

#### 3.3.1. Association Establishment Policies

##### 3.3.1.1. General

AE will utilize and understand the following Application Context Name:

**Table 3-9**

DICOM V3.0 Application Context	1.2.840.10008.3.1.1.1
--------------------------------	-----------------------

AE supports a minimum PDU size of 4Kbytes and a maximum PDU size of 32Kbytes.

The default value is set to 28Kbytes.

##### 3.3.1.2. Number of Associations

AE can only establish one association at a time, independent of the number of destinations chosen.

##### 3.3.1.3. Asynchronous Nature

AE allows a single outstanding operation on any association. Therefore, AE does not support asynchronous operations window negotiation, other than the default as specified by the DICOM specification.

##### 3.3.1.4. Implementation Identifying Information

AE will specify the following Implementation Identifying Information:

- Implementation Class UID                   1.2.392.200036.9116.7.8.12.10.31.1.1
- Implementation Version Name            TM\_INFINIX\_V1.0

#### 3.3.2. Association Initiation by Real-World Activity

AE initiates an association when the following activity is chosen by the operator.

- "Request for Study List"
  - ◆ Request Worklist     - Query and Retrieve Study List

##### 3.3.2.1. Real-World Activity – Request Worklist

###### 3.3.2.1.1. Associated Real-World Activity - Request Worklist

The operator specifies a search and sends the request to a remote DICOM device.

When the results of the search have been completely received, the association is released.

**3.3.2.1.2. Proposed Presentation Contexts - Request Worklist**

AE proposes the following Presentation Contexts shown below:

**Table 3-10**

<b>Presentation Context Table</b>					
<b>Abstract Syntax</b>		<b>Transfer Syntax</b>		<b>Role</b>	<b>Extended Negotiation</b>
<b>Name</b>	<b>UID</b>	<b>Name List</b>	<b>UID List</b>		
Modality Worklist Information Model-FIND	1.2.840.10008.5.1.4.31	Implicit VR Little Endian	1.2.840.10008.1.2	SCU	None
Modality Worklist Information Model-FIND	1.2.840.10008.5.1.4.31	Explicit VR Little Endian	1.2.840.10008.1.2.1	SCU	None

**3.3.2.1.2.1. SOP Specific Conformance - Request Worklist**

- Attributes are described in Chapter 10.

### 3.4. Modality Performed Procedure Step AE Specification

Modality Performed Procedure Step AE provides Standard Conformance to the following DICOM SOP Classes as an SCU:

*Table 3-11*

SOP Class Name	SOP Class UID
Modality Performed Procedure Step	1.2.840.10008.3.1.2.3.3

#### 3.4.1. Association Establishment Policies

##### 3.4.1.1. General

AE will utilize and understand the following Application Context Name:

*Table 3-12*

DICOM V3.0 Application Context	1.2.840.10008.3.1.1.1
--------------------------------	-----------------------

AE supports a minimum PDU size of 4Kbytes and a maximum PDU size of 32Kbytes.

The default value is set to 28Kbytes.

##### 3.4.1.2. Number of Associations

AE can only establish one association at a time, independent of the number of destinations chosen.

##### 3.4.1.3. Asynchronous Nature

AE allows a single outstanding operation on any association. Therefore, AE does not support asynchronous operations window negotiation, other than the default as specified by the DICOM specification.

##### 3.4.1.4. Implementation Identifying Information

AE will specify the following Implementation Identifying Information:

- Implementation Class UID                   1.2.392.200036.9116.7.8.12.10.31.1.1
- Implementation Version Name            TM\_INFINIX\_V1.0

#### 3.4.2. Association Initiation by Real-World Activity

AE initiates an association when the following activity is chosen by the operator.

- "Send of Study Results"
  - ◆ Modality Performed Procedure Step           - Create and send Modality Performed Procedure Step to a remote DICOM device

##### 3.4.2.1. Real-World Activity - Modality Performed Procedure Step

###### 3.4.2.1.1. Associated Real-World Activity - Modality Performed Procedure Step

AE performs the Modality Performed Procedure Step to a destination device. If a communication error occurs, the Modality Performed Procedure Step operation is automatically retried several times.

### 3.4.2.1.2. Proposed Presentation Contexts - Modality Performed Procedure Step

AE proposes the following Presentation Contexts shown below:

**Table 3-13**

<b>Presentation Context Table</b>					
<b>Abstract Syntax</b>		<b>Transfer Syntax</b>		<b>Role</b>	<b>Extended Negotiation</b>
<b>Name</b>	<b>UID</b>	<b>Name List</b>	<b>UID List</b>		
Modality Performed Procedure Step	1.2.840.10008.3.1.2.3.3	Implicit VR Little Endian	1.2.840.10008.1.2	SCU	None
Modality Performed Procedure Step	1.2.840.10008.3.1.2.3.3	Explicit VR Little Endian	1.2.840.10008.1.2. 1	SCU	None

#### 3.4.2.1.2.1. SOP Specific Conformance - Modality Performed Procedure Step

- Attributes are described in Chapter 11



### 3.5. Print AE Specification

Print AE provides Standard Conformance to the following DICOM SOP Classes as an SCU:

**Table 3-14**

SOP Class Name	SOP Class UID
Basic Grayscale Print Management	1.2.840.10008.5.1.1.9

The SOP Classes listed in Table 3-15 indicate the SOP Classes regulated by the Basic Grayscale Print Management Meta SOP Class.

**Table 3-15**

SOP Class Name	SOP Class UID
Basic Film Session SOP Class	1.2.840.10008.5.1.1.1
Basic Film Box SOP Class	1.2.840.10008.5.1.1.2
Basic Grayscale Image Box SOP Class	1.2.840.10008.5.1.1.4
Printer SOP Class	1.2.840.10008.5.1.1.16
Print Job SOP Class	1.2.840.10008.5.1.1.14

#### 3.5.1. Association Establishment Policies

##### 3.5.1.1. General

AE will utilize and understand the following Application Context Name:

**Table 3-16**

DICOM V3.0 Application Context	1.2.840.10008.3.1.1.1
--------------------------------	-----------------------

AE supports a minimum PDU size of 4Kbytes and a maximum PDU size of 32Kbytes.

The default value is set to 28Kbytes.

##### 3.5.1.2. Number of Associations

AE can only establish one association at a time, independent of the number of destinations chosen.

##### 3.5.1.3. Asynchronous Nature

AE allows a single outstanding operation on any association. Therefore, AE does not support asynchronous operations window negotiation, other than the default as specified by the DICOM specification.

##### 3.5.1.4. Implementation Identifying Information

AE will specify the following Implementation Identifying Information:

- Implementation Class UID 1.2.392.200036.9116.7.8.12.10.31.1.1

- Implementation Version Name TM\_INFINIX\_V1.0

### 3.5.2. Association Initiation by Real-World Activity

AE initiates an association when the following activity is chosen by the operator.

- "Print Image"
  - ◆ Print - Request print images to a remote DICOM device

#### 3.5.2.1. Real-World Activity - Print

##### 3.5.2.1.1. Associated Real-World Activity - Print

AE performs the Print to a destination device. If a communication error occurs, the Print operation is automatically retried several times.

##### 3.5.2.1.2. Proposed Presentation Contexts - Print

AE proposes the following Presentation Contexts shown below:

**Table 3-17**

Presentation Context Table					
Abstract Syntax		Transfer Syntax		Role	Extended Negotiation
Name	UID	Name List	UID List		
Basic Grayscale Print Management Meta SOP Class	1.2.840.10008.5.1.1.9	Implicit VR Little Endian	1.2.840.10008.1.2	SCU	None
		Explicit VR Little Endian	1.2.840.10008.1.2.1		
Basic Film Session SOP Class	1.2.840.10008.5.1.1.1	Implicit VR Little Endian	1.2.840.10008.1.2	SCU	None
		Explicit VR Little Endian	1.2.840.10008.1.2.1		
Basic Film Box SOP Class	1.2.840.10008.5.1.1.2	Implicit VR Little Endian	1.2.840.10008.1.2	SCU	None
		Explicit VR Little Endian	1.2.840.10008.1.2.1		
Basic Grayscale Image Box SOP Class	1.2.840.10008.5.1.1.4	Implicit VR Little Endian	1.2.840.10008.1.2	SCU	None
		Explicit VR Little Endian	1.2.840.10008.1.2.1		
Printer SOP Class	1.2.840.10008.5.1.1.16	Implicit VR Little Endian	1.2.840.10008.1.2	SCU	None

		Explicit VR Little Endian	1.2.840.10008.1.2. 1		
Print Job SOP Class	1.2.840.10008.5.1.1.14	Implicit VR Little Endian	1.2.840.10008.1.2	SCU	None
		Explicit VR Little Endian	1.2.840.10008.1.2. 1		

### 3.5.2.1.2.1. SOP Specific Conformance - Print

- Attributes are described in Chapter 12.

### 3.6. Query/Retrieve AE Specification

Query/Retrieve AE provides Standard Conformance to the following DICOM SOP Classes as an SCU:

**Table 3-18**

SOP Class Name	SOP Class UID
Patient Root Query/Retrieve Information Model - FIND	1.2.840.10008.5.1.4.1.2.1.1
Patient Root Query/Retrieve Information Model - MOVE	1.2.840.10008.5.1.4.1.2.1.2

#### 3.6.1. Association Establishment Policies

##### 3.6.1.1. General

AE will utilize and understand the following Application Context Name:

**Table 3-19**

DICOM V3.0 Application Context	1.2.840.10008.3.1.1.1
--------------------------------	-----------------------

AE supports a minimum PDU size of 4Kbytes and a maximum PDU size of 32Kbytes.

The default value is set to 28Kbytes.

##### 3.6.1.2. Number of Associations

AE can only establish one association at a time, independent of the number of destinations chosen.

##### 3.6.1.3. Asynchronous Nature

AE allows a single outstanding operation on any association. Therefore, AE does not support asynchronous operations window negotiation, other than the default as specified by the DICOM specification.

##### 3.6.1.4. Implementation Identifying Information

AE will specify the following Implementation Identifying Information:

- Implementation Class UID                   1.2.392.200036.9116.7.8.12.10.31.1.1
- Implementation Version Name            TM\_INFINIX\_V1.0

#### 3.6.2. Association Initiation by Real-World Activity

AE initiates an association when the following activity is chosen by the operator.

- "Query/Retrieve"
  - ◆ Query/Retrieve           - Query and Retrieve Patient and Study Information from a remote DICOM device

##### 3.6.2.1. Real-World Activity – Query/Retrieve

###### 3.6.2.1.1. Associated Real-World Activity – Query/Retrieve

AE performs the Query/Retrieve to a destination device. If a communication error occurs, the Query/Retrieve operation is automatically retried several times.

### 3.6.2.1.2. Proposed Presentation Contexts – Query/Retrieve

AE proposes the following Presentation Contexts shown below:

**Table 3-20**

<b>Presentation Context Table</b>					
<b>Abstract Syntax</b>		<b>Transfer Syntax</b>		<b>Role</b>	<b>Extended Negotiation</b>
<b>Name</b>	<b>UID</b>	<b>Name List</b>	<b>UID List</b>		
Patient Root Query/Retrieve Information Model - FIND	1.2.840.10008.5.1.4.1.2.1.1	Implicit VR Little Endian	1.2.840.10008.1.2	SCU	None
		Explicit VR Little Endian	1.2.840.10008.1.2.1		
Patient Root Query/Retrieve Information Model - MOVE	1.2.840.10008.5.1.4.1.2.1.2	Implicit VR Little Endian	1.2.840.10008.1.2	SCU	None
		Explicit VR Little Endian	1.2.840.10008.1.2.1		

#### 3.6.2.1.2.1. SOP Specific Conformance – FIND

- The Application conforms to the definition of FIND SCU in accordance with the DICOM Standard.

#### 3.6.2.1.2.2. SOP Specific Conformance – MOVE

- The Application conforms to the definition of MOVE SCU in accordance with the DICOM Standard.

### 3.7. Storage SCP Specification

Storage SCP AE provides Standard Conformance to the following DICOM SOP Classes as an SCP:

**Table 3-21**

SOP Class Name	SOP Class UID
XA Image Storage	1.2.840.10008.5.1.4.1.1.12.1

#### 3.7.1. Association Establishment Policies

##### 3.7.1.1. General

AE will utilize and understand the following Application Context Name:

**Table 3-22**

DICOM V3.0 Application Context	1.2.840.10008.3.1.1.1
--------------------------------	-----------------------

AE supports a minimum PDU size of 4Kbytes and a maximum PDU size of 32Kbytes.

The default value is set to 28Kbytes.

##### 3.7.1.2. Number of Associations

AE initiates association at a time, one for each storage request being processed.

##### 3.7.1.3. Asynchronous Nature

AE allows a single outstanding operation on any association. Therefore, Storage AE does not support asynchronous operations window negotiation, other than the default as specified by the DICOM specification.

##### 3.7.1.4. Implementation Identifying Information

AE will specify the following Implementation Identifying Information:

- Implementation Class UID 1.2.392.200036.9116.7.8.12.10.31.1.1
- Implementation Version Name TM\_INFINIX\_V1.0

### 3.7.2. Association Initiation by Real-World Activity

AE never initiates an association.

### 3.7.3. Association Acceptance Policy

AE accepts an association generated by remote applications.

"Receiving of images"

- Storage SCP - Receive images from a remote DICOM device

#### 3.7.3.1. Real-World Activity – Storage SCP

##### 3.7.3.1.1. Associated Real-World Activity – Storage SCP

When a request of Image Storage is sent by a remote system, an association is accepted.

##### 3.7.3.1.2. Proposed Presentation Contexts – Storage SCP

AE accepts the following Presentation Contexts shown below:

*Table 3-23*

Presentation Context Table					
Abstract Syntax		Transfer Syntax		Role	Extended Negotiation
Name	UID	Name List	UID List		
XA Image Storage	1.2.840.10008.5.1.4.1.1.12 .1	Implicit VR Little Endian	1.2.840.10008.1.2	SCP	None
XA Image Storage	1.2.840.10008.5.1.4.1.1.12 .1	Explicit VR Little Endian	1.2.840.10008.1.2. 1	SCP	None
XA Image Storage	1.2.840.10008.5.1.4.1.1.12 .1	*1	1.2.840.10008.1.2. 4.70	SCP	None

\*1:JPEG Lossless (Process 14 [Selection Value1])

##### 3.7.3.1.2.1. SOP Specific Conformance – Storage SCP

- The Application conforms to the definition of Storage SCP in accordance with the DICOM Standard.

### 3.8. DICOM Recording Specification

The DICOM Recording AE provides Standard Conformance to the DICOM Media Storage Service, File Format Class and the Media Storage Application Profile.

**Table 3-24**

Application Profile	Identifier	Real World Activity	Role	SC Option
Basic Cardiac X-ray Angiographic Studies on CD-R Media	STD-XABC-CD	Transfer of X-ray Examination	FSC	Interchange
Extended Cardiac X-ray Angiographic Studies on CD-R Media	AUG-XABC-CD	Transfer of X-ray Examination	FSC	Interchange

In case of DVD-RAM media, the Application Profiles described above are provisionally adopted.

#### 3.8.1. File Meta Information for the Application Entity

The Source Application Entity Title is set by Toshiba Service Personnel.

Configurable parameters are described in Chapter 7.

#### 3.8.2. Real-World Activity

##### 3.8.2.1. Real-World Activity - Transfer of X-ray Examination

DICOM Recording AE acts as an FSC when chosen by the operator. This AE writes the SOP instances onto the DICOM media, creates a DicomDIR and writes it onto the DICOM media.

#### 3.8.3. Media Storage Application Profile

DICOM Recording AE uses the Application Profile defined in Table 3-24.

#### 3.8.4. Information Object Definition and DicomDIR keys

Information Object Definition and DicomDIR keys are described in Chapter 9.



### 3.9. DICOM Reader Specification

The DICOM Reader AE provides Conformance to the DICOM Media Storage Service, File Format Class and the Media Storage Application Profile.

**Table 3-25**

Application Profile	Identifier	Real World Activity	Role	SC Option
Basic Cardiac X-ray Angiographic Studies on CD-R Media	STD-XABC-CD	Review of X-ray Examination	FSR	Interchange
Extended Cardiac X-ray Angiographic Studies on CD-R Media	AUG-XABC-CD	Review of X-ray Examination	FSR	Interchange

In case of DVD-RAM media, the Application Profiles described above are provisionally adopted.

#### 3.9.1. File Meta Information for the Application Entity

The Application Entity Title is not relevant because this DICOM Reader AE only reads DICOM media.

#### 3.9.2. Real-World Activity

##### 3.9.2.1. Real-World Activity - Review of X-ray Examination

DICOM Reader AE acts as an FSR when chosen by the operator. This AE reads the DICOMDIR from the DICOM media and reads the SOP instances from the DICOM media.

#### 3.9.3. Media Storage Application Profile

DICOM Reader AE uses the Application Profile defined in Table 3-25.

#### 3.9.4. Information Object Definition and DICOMDIR keys

Information Object Definition and DICOMDIR keys are described in Chapter 9.

## 4. Augmented and Private Application Profiles

### 4.1. Augmented Application Profiles

DICOM Reader AE supports Augmented Application Profile: AUG-XABC-CD.

This is an extension of the standard Application Profile: STD-XABC-CD.

#### 4.1.1. AUG-XABC-CD

##### 4.1.1.1. SOP Class Augmentations

None

##### 4.1.1.2. Directory Augmentations

None

##### 4.1.1.3. Other Augmentations

The following attributes used within the X-ray Angiographic Image files have the specified values.

**Table 4-1**

Attribute Name	Tag	Value
Modality	(0008, 0060)	XA
Rows	(0028, 0010)	512,1024,1024-8192*
Columns	(0028, 0011)	512,1024
Bits Allocated	(0028, 0100)	8, 16
Bits Stored	(0028, 0101)	8, 10, 12

\*: The value of rows is specified from 1024 to 8192 in case of panoramic view image (User option). In this case, Columns is only set to 1024, Bits Allocated is only set to 16 and Bits Stored is only set to 12.

### 4.2. Private Application Profiles

Not applicable to this product.

## **5. Communication Profiles**

### **5.1. Supported Communication Stacks**

This product provides DICOM TCP/IP Network Communication Support as defined in Part 8 of the DICOM Standard.

### **5.2. OSI Stack**

Not applicable to this product.

### **5.3. TCP/IP Stack**

This product inherits its TCP/IP stack from the computer system upon which it executes.

### **5.4. API**

Not applicable to this product.

#### **5.4.1. Physical Media Support**

This product is indifferent to the physical medium over which TCP/IP executes; it inherits the medium from the computer system upon which it executes.

### **5.5. Point-to-Point Stack**

Not applicable to this product.

## **6. Extensions/Specializations/Privatizations**

The standard Extended Attributes applied by this product are specified in private group 29 and 7079 as Type 3 data elements in the X-ray Angiographic IOD.

Due to these extensions, this product generates and recognizes private attributes identified with Private Creator strings "TOSHIBA COMAPL HEADER" and/or "TOSHIBA COMAPL OOG" for private group 29 and "TOSHIBA\_MEC\_XA3" for private group 7079.

## 7. Configuration

For the Digital Radiography System, the configuration can be set.

Note: Settings and changes are performed by Toshiba Service Personnel at the time of installation of the system.

### 7.1. AE Title/Presentation Address Mapping

Mapping from the AE titles to the presentation addresses are as follows:

- Each AE title is mapped to one port number.
- The Digital Radiography System has following default values:

Local AE Title                      INFINIX

Local Port No.                      104

- Embedded spaces in AE title are not allowed.

### 7.2. Implementation Information and Maximum Reception PDU Size

The default values for the Digital Radiography System are used for the Implementation Class UID, the Implementation Version Name, and the Maximum length received.

*Table 7-1*

Parameter	Default
Implementation Class UID	1.2.392.200036.9116.7.8.12.10.31.1.1
Implementation Version Name	TM_INFINIX_V1.0
Maximum length received (unit: byte)	32Kbytes

## **8. Support of Extended Character Sets**

This product supports the following character sets:

- ISO-IR 6 (default)      ISO 646
- ISO-IR 87 (Japanese) JIS X 0208(Kanji)
- ISO-IR 100 (Latin1) supplementary set of ISO 8859

## 9. X-Ray Angiographic Information Object Definition

### 9.1. Entity Module Definitions

The information modules for the X-Ray Angiographic devices are defined below.

#### 9.1.1. Media Storage Directory IOD Modules

*Table 9-1*

Object	Module / key	Reference	Usage <sup>1</sup>
DICOM File Meta Information		9.2.1	M
Basic Directory Information Object Definition	File-set Identification Module	9.3.1	M
	Directory Information Module	9.3.2	U
Definition of Specific Directory Records	PATIENT keys	9.4.1	M
	STUDY keys	9.4.2	M
	SERIES keys	9.4.3	M
	IMAGE keys	9.4.4	M

<sup>1</sup> M=Mandatory, C=Conditional, U=User option

#### 9.1.2. Media Storage XA IOD Modules

*Table 9-2*

Object	Module / key	Reference	Usage <sup>1</sup>
DICOM File Meta Information		9.2.2	M
XA Information Object Definition	XA IOD Modules	9.1.3	M

<sup>1</sup> M=Mandatory, C=Conditional, U=User option

### 9.1.3. XA IOD Modules

**Table 9-3**

Information Entity	Module	Reference	Usage <sup>1</sup>
Patient	Patient Module	9.5.1	M
Study	General Study Module	9.5.2	M
Study	Patient Study Module	9.5.3	U
Series	General Series Module	9.5.4	M
Equipment	General Equipment Module	9.5.5	M
Image	General Image Module	9.5.6	M
Image	Image Pixel Module	9.5.7	M
Image	Contrast/bolus Module	9.5.8	C
Image	Cine Module	9.5.9	C
Image	Multi-frame Module	9.5.10	C
Image	Frame Pointers Module	9.5.11	U
Image	Mask Module	9.5.12	C
Image	Display Shutter Module	9.5.13	U
Image	Device Module	9.5.14	U
Image	Therapy Module	9.5.15	U
Image	X-ray Image Module	9.5.16	M
Image	X-ray Acquisition Module	9.5.17	M
Image	X-ray Collimator Module	9.5.18	U
Image	X-ray Table Module	9.5.19	C
Image	XA Positioner Module	9.5.18	M
Image	Overlay Plane Module	9.5.21	U
Image	Multi-Frame Overlay Module	9.5.22	C
Image	Curve Module	9.5.23	U
Image	VOI LUT Module	9.5.24	U
Image	SOP Common Module	9.5.25	M

<sup>1</sup> M=Mandatory, C=Conditional, U=User option



## 9.2. DICOM File Meta Information

### 9.2.1. DICOM File Meta Information of Directory IOD

*Table 9-4*

Attribute Name	Tag	Type	Attribute Description
File Preamble	No Tag	1	Always set
DICOM Prefix	No Tag	1	Always set ("DICM")
Group Length	(0002, 0000)	1	Always set
File Meta Information Version	(0002, 0001)	1	Always set (0x0001)
Media Storage SOP Class UID	(0002, 0002)	1	Always set ("1.2.840.10008.1.3.10")
Media Storage SOP Instance UID	(0002, 0003)	1	Always set
Transfer Syntax UID	(0002, 0010)	1	Always set ("1.2.840.10008.1.2.1")
Implementation Class UID	(0002, 0012)	1	Always set

### 9.2.2. DICOM File Meta Information of XA IOD

*Table 9-5*

Attribute Name	Tag	Type	Attribute Description
File Preamble	No Tag	1	Always set
DICOM Prefix	No Tag	1	Always set ("DICM")
Group Length	(0002, 0000)	1	Always set
File Meta Information Version	(0002, 0001)	1	Always set (0x0001)
Media Storage SOP Class UID	(0002, 0002)	1	Always set ("1.2.840.10008.5.1.4.1.1.12.1")
Media Storage SOP Instance UID	(0002, 0003)	1	Always set
Transfer Syntax UID	(0002, 0010)	1	Always set
Implementation Class UID	(0002, 0012)	1	Always set
Implementation Version Name	(0002, 0013)	3	Always set

## 9.3. Basic Directory Information Object Definitions

### 9.3.1. File-set Identification Module

*Table 9-6*

Attribute Name	Tag	Type	Attribute Description
File-set ID	(0004, 1130)	2	Always set

### 9.3.2. Directory Information Module

**Table 9-7**

Attribute Name	Tag	Type	Attribute Description
Offset of the First Directory Record of the Root Directory Entity	(0004, 1200)	1	Always set
Offset of the Last Directory Record of the Root Directory Entity	(0004, 1202)	1	Always set
File-set Consistency Flag	(0004, 1212)	1	Always set
Directory Record Sequence	(0004, 1220)	2	Always set
>Offset of the Next Directory Record	(0004, 1400)	1C	Always set
>Record In-use Flag	(0004, 1410)	1C	Always set
>Offset of Referenced Lower-Level Directory Entity	(0004, 1420)	1C	Always set
>Directory Record Type	(0004, 1430)	1C	Always set
>Referenced File ID	(0004, 1500)	1C	Always set
>Referenced SOP Class UID in File	(0004, 1510)	1C	Required if the Directory Record references a SOP Instance.
>Referenced SOP Instance UID in File	(0004, 1511)	1C	Required if the Directory Record references a SOP Instance.
>Referenced Transfer Syntax UID in File	(0004, 1512)	1C	Required if the Directory Record references a SOP Instance.

### 9.4. Definition of Specific Directory Records

#### 9.4.1. PATIENT keys

**Table 9-8**

Attribute Name	Tag	Type	Attribute Description
Specific Character Set	(0008, 0005)	1C	Required if an expands or replacement character set is used.
Patient's Name	(0010, 0010)	2	Always set
Patient ID	(0010, 0020)	1	Always set
Patient's Birth Date	(0010, 0030)	2	Length=0 when no entry is made
Patient's Sex	(0010, 0040)	2	Always set

#### 9.4.2. STUDY keys

**Table 9-9**

Attribute Name	Tag	Type	Attribute Description
Specific Character Set	(0008, 0005)	1C	Required if an expands or replacement character set is used.
Study Date	(0008, 0020)	1	Always set

Study Time	(0008, 0030)	1	Always set
Study Description	(0008, 1030)	2	Length=0 when no entry is made
Study ID	(0020, 0010)	1	Always set
Accession Number	(0008, 0050)	2	Length=0 when no entry is made

### 9.4.3. SERIES keys

**Table 9-10**

Attribute Name	Tag	Type	Attribute Description
Specific Character Set	(0008, 0005)	1C	Required if an expands or replacement character set is used.
Modality	(0008, 0060)	1	Always set ("XA")
Series Instance UID	(0020, 000E)	1	Always set
Series Number	(0020, 0011)	1	Always set
Institution Name	(0008, 0080)	2	Always set
Institution Address	(0008, 0081)	2	Always set
Performing Physician's Name	(0008, 1050)	2	Length=0 when no entry is made

### 9.4.4. IMAGE keys

**Table 9-11**

Attribute Name	Tag	Type	Attribute Description
Specific Character Set	(0008, 0005)	1C	Required if an expands or replacement character set is used.
Image Number	(0020, 0013)	1	Always set
Image Type	(0008, 0008)	1	Always set
Image Date	(0008, 0023)	3	Always set
Image Time	(0008, 0033)	3	Always set
Referenced Image Sequence	(0008, 1140)	1C	Not set when Image type(0008,0008) Value 3 is "SINGLE PLANE"
>Referenced SOP Class UID	(0008, 1150)	1C	Always set when Reference Image Sequence is present
>Referenced SOP Instance UID	(0008, 1155)	1C	Always set when Reference Image Sequence is present
Positioner Primary Angle	(0018, 1510)	3	Always set [degree]
Positioner Secondary Angle	(0018, 1511)	3	Always set [degree]
Image Comments	(0020, 4000)	3	Length=0 when no entry is made
Number of Frames	(0028, 0008)	3	Always set
Calibration Image	(0050, 0004)	2	Length=0 when no entry is made
Icon Image Sequence	(0088, 0200)	1	Always set
>Samples per Pixel	(0028, 0002)	1	Always set (0x0001)
>Photometric Interpretation	(0028, 0004)	1	Always set ("MONOCHROME2")

>Rows	(0028, 0010)	1	Always set (0x0080)
>Columns	(0028, 0011)	1	Always set (0x0080)
>Bits Allocated	(0028, 0100)	1	Always set (0x0008)
>Bits Stored	(0028, 0101)	1	Always set (0x0008)
>High Bit	(0028, 0102)	1	Always set (0x0007)
>Pixel Representation	(0028, 0103)	1	Always set (0x0000)
>Pixel Data	(7FE0, 0010)	1	Always set

## 9.5. XA Information Object Definitions

### 9.5.1. Patient Module

**Table 9-12**

Attribute Name	Tag	Type	Attribute Description
Patient's Name	(0010, 0010)	2	Always set except for urgent patient
Patient ID	(0010, 0020)	2	Always set
Patient's Birth Date	(0010, 0030)	2	Length=0 when no entry is made
Patient's Sex	(0010, 0040)	2	Always set
Other Patient Ids	(0010,1000)	3	Not set when no data is available
Other Patient Names	(0010,1001)	3	Not set when no data is available
Ethnic Group	(0010,2160)	3	Not set when no data is available
Patient Comments	(0010, 4000)	3	Not set when no data is available

### 9.5.2. General Study Module

**Table 9-13**

Attribute Name	Tag	Type	Attribute Description
Study Instance UID	(0020, 000D)	1	Always set
Study Date	(0008, 0020)	2	Always set
Study Time	(0008, 0030)	2	Always set
Referring Physician's Name	(0008, 0090)	2	Length=0 when no entry is made
Study ID	(0020, 0010)	2	Always set
Accession Number	(0008, 0050)	2	Length=0 when no entry is made
Study Description	(0008, 1030)	3	Length=0 when no entry is made
Physician(s) of Record	(0008, 1048)	3	Not set when no data is available
Name of Physician(s) Reading Study	(0008, 1060)	3	Not set when no data is available

### 9.5.3. Patient Study Module

**Table 9-14**

Attribute Name	Tag	Type	Attribute Description
Patient's Age	(0010, 1010)	3	Length=0 when no entry is made
Patient's Size	(0010, 1020)	3	Not set when no data is available
Patient's Weight	(0010, 1030)	3	Not set when no data is available
Occupation	(0010, 2180)	3	Length=0 when no entry is made
Additional Patient's History	(0010, 21B0)	3	Length=0 when no entry is made

#### 9.5.4. General Series Module

**Table 9-15**

Attribute Name	Tag	Type	Attribute Description
Modality	(0008, 0060)	1	Always set ("XA")
Series Instance UID	(0020, 000E)	1	Always set
Series Number	(0020, 0011)	2	Always set
Series Date	(0008, 0021)	3	Always set
Series Time	(0008, 0031)	3	Always set
Performing Physician's Name	(0008, 1050)	3	Not set when no data is available
Protocol Name	(0018, 1030)	3	Length=0 when no entry is made
Series Description	(0008, 103E)	3	Not set when no data is available
Operators' Name	(0008, 1070)	3	Not set when no data is available
Body Part Examined	(0018,0015)	3	Not set when no data is available
Performed Procedure Step ID	(0040, 0253)	3	Not set when no data is available
Performed Procedure Step Start Date	(0040, 0244)	3	Not set when no data is available
Performed Procedure Step Start Time	(0040, 0245)	3	Not set when no data is available
Performed Procedure Step Description	(0040, 0254)	3	Not set when no data is available

#### 9.5.5. General Equipment Module

**Table 9-16**

Attribute Name	Tag	Type	Attribute Description
Manufacturer	(0008, 0070)	2	Always set
Institution Name	(0008, 0080)	3	Always set
Institution Address	(0008, 0081)	3	Always set
Station Name	(0008, 1010)	3	Always set
Institutional Department Name	(0008, 1040)	3	Length=0 when no entry is made
Manufacturer's Model Name	(0008, 1090)	3	Always set
Device Serial Number	(0018, 1000)	3	Always set
Software Versions	(0018, 1020)	3	Always set
Spatial Resolution	(0018, 1050)	3	Not set when no data is available
Date of Last Calibration	(0018, 1200)	3	Not set when no data is available
Pixel Padding Value	(0028, 0120)	3	Not set when no data is available

#### 9.5.6. General Image Module

**Table 9-17**

Attribute Name	Tag	Type	Attribute Description
Image Number	(0020, 0013)	2	Always set

Patient Orientation	(0020, 0020)	2C	Always set
Image Date	(0008, 0023)	2C	Always set
Image Time	(0008, 0033)	2C	Always set
Image Type	(0008, 0008)	3	Always set
Acquisition Number	(0008, 0012)	3	Always set
Acquisition Date	(0008, 0022)	3	Always set
Acquisition Time	(0008, 0032)	3	Always set
Referenced Image Sequence	(0008,1140)	3	Not set when Image type(0008,0008) Value 3 is "SINGLE PLANE"
>Referenced SOP Class UID	(0008, 1150)	1C	Always set when Reference Image Sequence is present
>Referenced SOP Instance UID	(0008, 1155)	1C	Always set when Reference Image Sequence is present
Image Comments	(0020, 4000)	3	Length=0 when no entry is made

### 9.5.7. Image Pixel Module

**Table 9-18**

Attribute Name	Tag	Type	Attribute Description
Samples per Pixel	(0028, 0002)	1	Always set (0x0001)
Photometric Interpretation	(0028, 0004)	1	Always set ("MONOCHROME2")
Rows	(0028, 0010)	1	Always set
Columns	(0028, 0011)	1	Always set
Bits Allocated	(0028, 0100)	1	Always set
Bits Stored	(0028, 0101)	1	Always set
High Bit	(0028, 0102)	1	Always set
Pixel Representation	(0028, 0103)	1	Always set
Pixel Data	(7FE0, 0010)	1	Always set

### 9.5.8. Contrast/Bolus Module

**Table 9-19**

Attribute Name	Tag	Type	Attribute Description
Contrast/Bolus Agent	(0018, 0010)	2	Length=0 when no entry is made
Contrast/Bolus Route	(0018, 1040)	3	Not set when no data is available
Contrast/Bolus Volume	(0018, 1041)	3	Not set when no data is available
Contrast/Bolus Start Time	(0018, 1042)	3	Not set when no data is available
Contrast/Bolus Stop Time	(0018, 1043)	3	Not set when no data is available
Contrast Flow Rate(s)	(0018, 1046)	3	Not set when no data is available
Contrast Flow Duration(s)	(0018, 1047)	3	Not set when no data is available
Contrast/Bolus Ingredient	(0018, 1048)	3	Not set when no data is available

Contrast/Bolus Ingredient Concentration	(0018, 1049)	3	Not set when no data is available
---	--------------	---	-----------------------------------

### 9.5.9. Cine Module

**Table 9-20**

Attribute Name	Tag	Type	Attribute Description
Frame Time	(0018, 1063)	1C	Set when DA acquisition or fluoroscopy recording is performed
Frame Time Vector	(0018, 1065)	1C	Always set
Start Trim	(0008, 2142)	3	Not set when no data is available
Stop Trim	(0008, 2143)	3	Not set when no data is available
Recommended Display Frame Rate	(0008, 2144)	3	Always set
Cine Rate	(0018, 0040)	3	Not set when no data is available
Frame Delay	(0018, 1066)	3	Not set when no data is available
Image Trigger Delay	(0018, 1067)	3	Not set when no data is available
Effective Duration	(0018, 0072)	3	Not set when no data is available
Actual Frame Duration	(0018, 1242)	3	Not set when no data is available

### 9.5.10. Multi-frame Module

**Table 9-21**

Attribute Name	Tag	Type	Attribute Description
Number of Frames	(0028, 0008)	1	Always set
Frame Increment Pointer	(0028, 0009)	1	Always set (0x00181063 / 0x00181065)

### 9.5.11. Frame Pointers Module

**Table 9-22**

Attribute Name	Tag	Type	Attribute Description
Representative Frame Number	(0028, 6010)	3	Length=0 when no entry is made
Frame Numbers Of Interest (FOI)	(0028, 6020)	3	Length=0 when no entry is made
Frame Of Interest Description	(0028, 6022)	3	Length=0 when no entry is made

### 9.5.12. Mask Module

Mask Module is not always set.

**Table 9-23**

Attribute Name	Tag	Type	Attribute Description
----------------	-----	------	-----------------------



Mask Subtraction Sequence	(0028, 6100)	1	Always set
>Mask Operation	(0028, 6101)	1	Always set "NONE"/"AVG_SUB"/"TID"
>Mask Frame Number	(0028, 6110)	1C	Set when Mask Operation is AVG_SUB
>Contract Frame Averaging	(0028, 6112)	3	Not set when no data is available
>Mask Sub-pixel Shift	(0028, 6114)	3	Not set when no data is available
>TID Offset	(0028, 6120)	2C	Set when Mask Operation is TID.
>Mask Operation Explanation	(0028, 6190)	3	Not set when no data is available
Recommended Viewing Mode	(0028, 1090)	2	Length=0 when no entry is made "SUB"/"NAT"

### 9.5.13. Display Shutter Module

Display Shutter Module is set when image is applied by Display Shutter.

**Table 9-24**

Attribute Name	Tag	Type	Attribute Description
Shutter Shape	(0018, 1600)	1	Always set "RECTANGULAR"
Shutter Left Vertical Edge	(0018, 1602)	1C	Set when Mask Operation is RECTANGULAR
Shutter Right Vertical Edge	(0018, 1604)	1C	Set when Mask Operation is RECTANGULAR
Shutter Upper Horizontal Edge	(0018, 1606)	1C	Set when Mask Operation is RECTANGULAR
Shutter Lower Horizontal Edge	(0018, 1608)	1C	Set when Mask Operation is RECTANGULAR
Shutter Presentation Value	(0018, 1622)	3	Not set when no data is available

### 9.5.14. Device Module

**Table 9-25**

Attribute Name	Tag	Type	Attribute Description
Device Sequence	(0050, 0010)	3	Not set when no data is available
>Device Length	(0050, 0014)	3	Not set when no data is available
>Device Diameter	(0050, 0016)	3	Not set when no data is available
>Device Diameter units	(0050, 0017)	2C	Set when Device Sequence is present
>Device Volume	(0050, 0018)	3	Not set when no data is available
>Inter-marker Distance	(0050, 0019)	3	Not set when no data is available
>Device Description	(0050, 0020)	3	Not set when no data is available

### 9.5.15. Therapy Module

**Table 9-26**

Attribute Name	Tag	Type	Attribute Description
Interventional Therapy Sequence	(0018, 0036)	3	Not set when no data is available
>Interventional Status	(0018, 0038)	2	"PRE"/"INTERMEDIATE"/"POST"/"NONE"

### 9.5.16. X-ray Image Module

**Table 9-27**

Attribute Name	Tag	Type	Attribute Description
Frame Increment Pointer	(0028, 0009)	1C	Always set (0x00181063 / 0x00181065)
Image Type	(0008, 0008)	1	Always set
Pixel Intensity Relationship	(0028, 1040)	1	Always set ("DISP" or "LIN")
Samples per Pixel	(0028, 0002)	1	Always set (0x0001)
Photometric Interpretation	(0028, 0004)	1	Always set ("MONOCHROME2")
Bits Allocated	(0028, 0100)	1	Always set
Bits Stored	(0028, 0101)	1	Always set
High Bit	(0028, 0102)	1	Always set
Pixel Representation	(0028, 0103)	1	Always set (0x0000)
Reference Image Sequence	(0008, 1140)	1C	Not set when Image type(0008,0008) Value 3 is "SINGLE PLANE"
>Reference SOP Class UID	(0008, 1150)	1C	Always set when Reference Image Sequence is present
>Reference SOP Instance UID	(0008, 1155)	1C	Always set when Reference Image Sequence is present
Calibration Image	(0050, 0004)	3	Not set when no data is available

### 9.5.17. X-ray Acquisition Module

**Table 9-28**

Attribute Name	Tag	Type	Attribute Description
KVP	(0018, 0060)	2	Always set [kV]
Radiation Setting	(0018, 1155)	1	Always set
X-ray Tube Current	(0018, 1151)	2C	Always set [mA]
Exposure Time	(0018, 1150)	2C	Always set [msec]
Grid	(0018, 1166)	3	Not set when no data is available
Average Pulse Width	(0018, 1154)	3	Always set [msec]
Radiation Mode	(0018, 115A)	3	Not set when no data is available
Type of Filters	(0018, 1161)	3	Not set when no data is available
Intensifier Size	(0018, 1162)	3	Always set [mm]
Field of View Shape	(0018, 1147)	3	Always set("ROUND"/"RECTANGLE")
Field of View Dimension(s)	(0018, 1149)	3	Always set [mm]

Imager Pixel Spacing	(0018, 1164)	3	Always set [mm]
Focal Spot	(0018, 1190)	3	Not set when no data is available
Image Area Dose Product	(0018, 115E)	3	Not set when no data is available

### 9.5.18. X-ray Collimator Module

**Table 9-29**

Attribute Name	Tag	Type	Attribute Description
Collimator Shape	(0018, 1700)	1	Always set "RECTANGULAR"/"CIRCULAR"
Collimator Left Vertical Edge	(0018, 1702)	1C	Set when Collimator Shape is RECTANGULAR
Collimator Right Vertical Edge	(0018, 1704)	1C	Set when Collimator Shape is RECTANGULAR
Collimator Upper Horizontal Edge	(0018, 1706)	1C	Set when Collimator Shape is RECTANGULAR
Collimator Lower Horizontal Edge	(0018, 1708)	1C	Set when Collimator Shape is RECTANGULAR
Center of Circular Collimator	(0018, 1710)	1C	Set when Collimator Shape is CIRCULAR
Radius of Circular Collimator	(0018, 1712)	1C	Set when Collimator Shape is CIRCULAR

### 9.5.19. X-ray Table Module

**Table 9-30**

Attribute Name	Tag	Type	Attribute Description
Table Motion	(0018, 1134)	2	"STATIC"/"DYNAMIC"
Table Vertical Increment	(0018, 1135)	2C	Set when Table Motion is DYNAMIC
Table Longitudinal Increment	(0018, 1137)	2C	Set when Table Motion is DYNAMIC
Table Lateral Increment	(0018, 1136)	2C	Set when Table Motion is DYNAMIC
Table Angle	(0018, 1138)	3	Not set when no data is available

### 9.5.20. XA Positioner Module

**Table 9-31**

Attribute Name	Tag	Type	Attribute Description
Distance Source to Patient	(0018, 1111)	3	Not set when no data is available
Distance Source to Detector	(0018, 1110)	3	Always set [mm]
Estimated Radiographic Magnification Factor	(0018, 1114)	3	Not set when no data is available
Positioner Motion	(0018, 1500)	2C	Always set ("STATIC"/"DYNAMIC")

Positioner Primary Angle	(0018, 1510)	2	Always set [degree]
Positioner Secondary Angle	(0018, 1511)	2	Always set [degree]
Positioner Primary Angle Increment	(0018, 1520)	2C	Set when Positioner Motion is DYNAMIC
Positioner Secondary Angle Increment	(0018, 1521)	2C	Set when Positioner Motion is DYNAMIC

### 9.5.21. Overlay Plane Module

**Table 9-32**

Attribute Name	Tag	Type	Attribute Description
Overlay Rows	(60xx, 0010)	1	Always set
Overlay Columns	(60xx, 0011)	1	Always set
Overlay Type	(60xx, 0040)	1	Always set
Overlay Origin	(60xx, 0050)	1	Always set
Overlay Bits Allocated	(60xx, 0100)	1	Always set
Overlay Bit Position	(60xx, 0102)	1	Always set
Overlay Data	(60xx, 3000)	1C	Set when Overlay Data are in this Group
Overlay Description	(60xx, 0022)	3	Not set when no data is available

### 9.5.22. Multi-Frame Overlay Module

**Table 9-33**

Attribute Name	Tag	Type	Attribute Description
Number of Frames in Overlay	(60xx, 0015)	1	Always set
Image Frame Origin	(60xx, 0051)	3	Not set when no data is available

### 9.5.23. Curve Module

**Table 9-34**

Attribute Name	Tag	Type	Attribute Description
Curve Dimensions	(50xx, 0005)	1	Always set
Number of Points	(50xx, 0010)	1	Always set
Type of Data	(50xx, 0020)	1	Always set
Data Value Representation	(50xx, 0103)	1	Always set
Curve Data	(50xx, 3000)	1	Always set
Curve Description	(50xx, 0022)	3	Not set when no data is available
Axis Units	(50xx, 0030)	3	Always set
Curve Data Descriptor	(50xx, 0110)	1C	Always set
Coordinate Start Value	(50xx, 0112)	1C	Always set

Coordinate Step Value	(50xx, 0114)	1C	Always set
-----------------------	--------------	----	------------

#### 9.5.24. VOI LUT Module

**Table 9-35**

Attribute Name	Tag	Type	Attribute Description
VOI LUT Sequence	(0028, 3010)	3	Not set when no data is available
>LUT Descriptor	(0028, 3002)	1C	Set when VOI LUT Sequence is present
>LUT Explanation	(0028, 3003)	3	Not set when no data is available
>LUT Data	(0028, 3006)	1C	Set when VOI LUT Sequence is present

#### 9.5.25. SOP Common Module

**Table 9-36**

Attribute Name	Tag	Type	Attribute Description
Specific Character Set	(0008, 0005)	1C	Required if an expands or replacement character set is used.
SOP Class UID	(0008, 0016)	1	Always set
SOP Instance UID	(0008, 0018)	1	Always set

## 10. Modality Worklist Management Information Object Definition

The attributes listed in the following tables represent a small set of the possible attributes which could be supported by a Modality Worklist Management SCU.

### 10.1. Matching Key Attributes

The supported Matching Key Attributes are listed as follows.

#### 10.1.1. Scheduled Procedure Step Module

*Table 10-1*

Description / Module	Tag	Matching Key Type	Matching Type
Scheduled Procedure Step Sequence	(0040, 0100)	Required	Sequence Matching.
>Scheduled station AE title	(0040, 0001)	Required	Single Value Matching only.
>Scheduled Procedure Step Start Date	(0040, 0002)	Required	Single Value Matching or Range Matching.
>Modality	(0008, 0060)	Required	"XA".

### 10.2. Return Key Attributes

The supported Return Key Attributes are listed as follows.

#### 10.2.1. SOP Common Module

*Table 10-5*

Description / Module	Tag	Return Key Type	Remarks
Specific Character Set	(0008,0005)	1C	Required if an expands or replacement character set is used.

#### 10.2.2. Scheduled Procedure Step Module

*Table 10-6*

Description / Module	Tag	Return Key Type	Remarks
Scheduled Procedure Step Sequence	(0040, 0100)	1	
>Scheduled station AE title	(0040, 0001)	1	
>Scheduled Procedure Step Start Date	(0040, 0002)	1	
>Scheduled Procedure Step Start Time	(0040, 0003)	1	
>Scheduled Procedure Step End Date	(0040, 0004)	3	
>Scheduled Procedure Step End Time	(0040, 0005)	3	
>Modality	(0008, 0060)	1	
>Scheduled Performing Physician's Name	(0040, 0006)	2	
>Scheduled Procedure Step Description	(0040, 0007)	1C	
>Scheduled Station Name	(0040,0010)	2	

>Scheduled Procedure Step Location	(0040,0011)	2	
>Scheduled Action Item Code Sequence	(0040,0008)	1C	
>>Code Value	(0008,0100)	1C	
>>Coding Scheme Designator	(0008,0102)	1C	
>>Coding Scheme Version	(0008,0103)	3	
>>Code Meaning	(0008,0104)	3	
>Pre-Medication	(0040, 0012)	2C	
>Scheduled Procedure Step ID	(0040, 0009)	1	
>Requested Contrast Agent	(0032, 1070)	2C	
>Scheduled Procedure Step Status	(0040, 0020)	3	
>Comments on the Scheduled Procedure Step	(0040, 0400)	3	

### 10.2.3. Requested Procedure Module

*Table 10-7*

Description / Module	Tag	Return Key Type	Remarks
Requested Procedure ID	(0040, 1001)	1	
Requested Procedure Description	(0032,1060)	1C	
Requested Procedure Code Sequence	(0032,1064)	1C	
>Code Value	(0008,0100)	1C	
>Coding Scheme Designator	(0008,0102)	1C	
>Coding Scheme Version	(0008,0103)	3	
>Code Meaning	(0008,0104)	3	
Study Instance UID	(0020, 000D)	1	
Referenced Study Sequence	(0008, 1110)	2	
>Referenced SOP Class UID	(0008, 1150)	1C	
>Referenced SOP Instance UID	(0008, 1155)	1C	
Requested Procedure Priority	(0040,1003)	2	
Patient Transport Arrangements	(0040,1004)	2	
Reason for the Requested Procedure	(0040,1002)	3	
Confidentiality Code	(0040,1008)	3	
Reporting Priority	(0040,1009)	3	
Names of Intended Recipients of results	(0040,1010)	3	
Requested Procedure Comments	(0040,1400)	3	
Requested Procedure Location	(0040,1005)	3	

### 10.2.4. Imaging Service Request Module

*Table 10-8*

Description / Module	Tag	Return Key Type	Remarks
----------------------	-----	-----------------	---------

Accession Number	(0008,0050)	2	
Requesting Physician	(0032,1032)	2	
Referring Physician's Name	(0008,0090)	2	
Reason for the Imaging Service Request	(0040,2001)	3	
Imaging Service Request Comments	(0040,2400)	3	
Requesting Service	(0032,1033)	3	
Issuing Date of Imaging Service Request	(0040,2004)	3	
Issuing Time of Imaging Service Request	(0040,2005)	3	
Placer Order Number / Imaging Service Request	(0040,2016)	3	
Filler Order Number / Imaging Service Request	(0040,2017)	3	
Order entered by...	(0040,2008)	3	
Order Enterer's Location	(0040,2009)	3	
Order Callback Phone Number	(0040,2010)	3	

### 10.2.5. Visit Identification Module

*Table 10-9*

Description / Module	Tag	Return Key Type	Remarks
Institution Name	(0008,0080)	3	
Institution Address	(0008,0081)	3	
Admission ID	(0038,0010)	2	
Issuer of Admission ID	(0038,0011)	3	

### 10.2.6. Visit Status Module

*Table 10-10*

Description / Module	Tag	Return Key Type	Remarks
Current Patient Location	(0038,0300)	2	

### 10.2.7. Visit Relationship Module

*Table 10-11*

Description / Module	Tag	Return Key Type	Remarks
Referenced Patient Sequence	(0008,1120)	2	
>Referenced SOP Class UID	(0008,1150)	2	
>Referenced SOP Instance UID	(0008,1155)	2	



**10.2.8. Visit Admission Module****Table 10-12**

Description / Module	Tag	Return Key Type	Remarks
Institution Name	(0008,0080)	2	
Admitting Diagnoses Description	(0008,1080)	2	

**10.2.9. Patient Identification Module****Table 10-13**

Description / Module	Tag	Return Key Type	Remarks
Patient's Name	(0010,0010)	1	
Patient ID	(0010,0020)	1	
Other Patient IDs	(0010,1000)	3	
Other Patient Names	(0010,1001)	3	

**10.2.10. Patient Demographic Module****Table 10-14**

Description / Module	Tag	Return Key Type	Remarks
Patient's Birth Date	(0010,0030)	2	
Patient's Sex	(0010,0040)	2	
Patient's Size	(0010,1020)	3	
Patient's Weight	(0010,1030)	2	
Confidentiality constraint on patient data	(0040,3001)	2	
Patient's Address	(0010,1040)	3	
Military Rank	(0010,1080)	3	
Ethnic Group	(0010,2160)	3	
Patient Comments	(0010,4000)	3	

**10.2.11. Patient Medical Module****Table 10-15**

Description / Module	Tag	Return Key Type	Remarks
Patient State	(0038,0500)	2	
Pregnancy Status	(0010,21C0)	2	
Medical Alerts	(0010,2000)	2	
Contrast Allergies	(0010,2110)	2	
Special Needs	(0038,0050)	2	
Smoking Status	(0010,21A0)	3	

Last Menstrual Date	(0010,21D0)	3	
Additional Patient History	(0010,21B0)	3	

## 11. Modality Performed Procedure Step Information Object Definition

The attributes listed in the following tables represent a small set of the possible attributes which could be supported by a Modality Performed Procedure Step SCU.

### 11.1. Modality Performed Procedure Step IOD Modules

#### 11.1.1. N-CREATE

*Table 11-1*

<b>Module</b>	<b>Reference</b>
SOP Common Module	11.2.1
Performed Procedure Step Relationship Module	11.2.2
Performed Procedure Step Information Module	11.2.3
Image Acquisition Results Module	11.2.4
Radiation Dose Module	Not used
Billing and Material Management Codes Module	Not used

#### 11.1.2. N-SET

*Table 11-2*

<b>Module</b>	<b>Reference</b>
SOP Common Module	Not used
Performed Procedure Step Relationship Module	Not used
Performed Procedure Step Information Module	11.3.1
Image Acquisition Results Module	11.3.2
Radiation Dose Module	11.3.3
Billing and Material Management Codes Module	11.3.4

## 11.2. N-CREATE Attributes

### 11.2.1. SOP Common Module

**Table 11-3**

Attribute Name	Tag	Type	Attribute Description
Specific Character Set	(0008,0005)	1C	Set if an extended or replacement character set is used

### 11.2.2. Performed Procedure Step Relationship Module

**Table 11-4**

Attribute Name	Tag	Type	Attribute Description
Scheduled Step Attribute Sequence	(0040,0270)	1	Always set
>Study Instance UID	(0020,000D)	1	Always set
>Referenced Study Sequence	(0008,1110)	2	Always set, length=0
>>Referenced SOP Class UID	(0008,1150)	1C	
>>Referenced SOP Instance UID	(0008,1155)	1C	
>Accession Number	(0008,0050)	2	Length=0 when no entry is made
>Placer Order Number / Imaging Service Request	(0040,2016)	3	No set when no entry is made
> Filler Order Number / Imaging Service Request	(0040,2017)	3	No set when no entry is made
>Requested Procedure ID	(0040,1001)	2	Length=0 when no entry is made
>Requested Procedure Description	(0032,1060)	2	Length=0 when no entry is made
>Scheduled Procedure Step Description	(0040,0007)	2	Length=0 when no entry is made
>Scheduled Action Item Code Sequence	(0040,0008)	2	Length=0 when no entry is made
>>Code Value	(0008,0100)	1C	Set if sequence item is present
>>Coding Scheme Designator	(0008,0102)	1C	Set if sequence item is present
>>Coding Scheme Version	(0008,0103)	3	Not set when no entry is made
>>Code Meaning	(0008,0104)	3	Not set when no entry is made
>Scheduled Procedure Step ID	(0040,0009)	2	Length=0 when no entry is made
Patient's Name	(0010,0010)	2	Always set
Patient ID	(0010,0020)	2	Always set
Patient's Birth Date	(0010,0030)	2	Length=0 when no entry is made
Patient's Sex	(0010,0040)	2	Length=0 when no entry is made
Referenced Patient Sequence	(0008,1120)	2	Always set, length=0
>Referenced SOP Class UID	(0008,1150)	1C	
>Referenced SOP Instance UID	(0008,1155)	1C	

### 11.2.3. Performed Procedure Step Information Module

*Table 11-5*

Attribute Name	Tag	Type	Attribute Description
Performed Procedure Step ID	(0040,0253)	1	Always set
Performed Station AE Title	(0040,0241)	1	Always set
Performed Station Name	(0040,0242)	2	Length=0 when no entry is made
Performed Location	(0040,0243)	2	Length=0 when no entry is made
Performed Procedure Step Start Date	(0040,0244)	1	Always set
Performed Procedure Step Start Time	(0040,0245)	1	Always set
Performed Procedure Step End Date	(0040,0250)	2	Length=0 when no entry is made
Performed Procedure Step End Time	(0040,0251)	2	Length=0 when no entry is made
Performed Procedure Step Status	(0040,0252)	1	Always set ("IN PROGRESS")
Performed Procedure Step Description	(0040,0254)	2	Length=0 when no entry is made
Performed Procedure Type Description	(0040,0255)	2	Always set, length=0
Procedure Code Sequence	(0008,1032)	2	Length=0 when no entry is made
>Code Value	(0008,0100)	1C	Set if sequence item is present
>Coding Scheme Designator	(0008,0102)	1C	Set if sequence item is present
>Coding Scheme Version	(0008,0103)	3	Not set when no entry is made
>Code Meaning	(0008,0104)	3	Not set when no entry is made

### 11.2.4. Image Acquisition Results Module

*Table 11-6*

Attribute Name	Tag	Type	Attribute Description
Modality	(0008,0060)	1	Always set ("XA")
Study ID	(0020,0010)	2	Always set
Performed Action Item Code Sequence	(0040,0260)	2	Length=0 when no entry is made
>Code Value	(0008,0100)	1C	Set if sequence item is present
>Coding Scheme Designator	(0008,0102)	1C	Set if sequence item is present
>Coding Scheme Version	(0008,0103)	3	Not set when no entry is made
>Code Meaning	(0008,0104)	3	Not set when no entry is made
Performed Series Sequence	(0040,0340)	2	Length=0 when no entry is made
>Performing Physician's Name	(0008,1050)	2C	Length=0 when no entry is made
>Operator's Name	(0008,1070)	2C	Length=0 when no entry is made
>Protocol Name	(0018,1030)	1C	Set if sequence item is present
>Series Instance UID	(0020,000E)	1C	Set if sequence item is present
>Series Description	(0008,103E)	2C	Always set, length=0
>Retrieve AE Title	(0008,0054)	2C	Always set, length=0
>Referenced Image Sequence	(0008,1140)	2C	Always set, length=0

>Referenced Standalone SOP Instance Sequence	(0040,0220)	2C	Always set, length=0
--	-------------	----	----------------------

### 11.3. N-SET Attributes

#### 11.3.1. Performed Procedure Step Information Module

*Table 11-7*

Attribute Name	Tag	Type (*1)	Attribute Description
Procedure Code Sequence	(0008,1032)	3	Length=0 when no entry is made
>Code Value	(0008,0100)	1C	Set if sequence item is present
>Coding Scheme Designator	(0008,0102)	1C	Set if sequence item is present
>Coding Scheme Version	(0008,0103)	3	Not set when no entry is made
>Code Meaning	(0008,0104)	3	Not set when no entry is made
Performed Procedure Step Status	(0040,0252)	3	Always set ("COMPLETED" or "DISCONTINUED")
Performed Procedure Step Description	(0040,0254)	3	Not set when no entry is made
Performed Procedure Type Description	(0040,0255)	3	Not set when no entry is made
Performed Procedure Step End Date	(0040,0250)	3 (1)	Always set
Performed Procedure Step End Time	(0040,0251)	3 (1)	Always set
Comments on the Performed Procedure Steps	(0040,0280)	3	Not set when no entry is made

\*1) Requirement Type Final State

#### 11.3.2. Image Acquisition Results Module

*Table 11-8*

Attribute Name	Tag	Type (*1)	Attribute Description
Performed Action Item Code Sequence	(0040,0260)	3	Length=0 when no entry is made
>Code Value	(0008,0100)	1C	Set if sequence item is present
>Coding Scheme Designator	(0008,0102)	1C	Set if sequence item is present
>Coding Scheme Version	(0008,0103)	3	Not set when no entry is made
>Code Meaning	(0008,0104)	3	Not set when no entry is made
Performed Series Sequence	(0040,0340)	3(1)	Always set
>Retrieve AE Title	(0008,0054)	2C(2)	Always set, length=0
>Series Description	(0008,103E)	2C(2)	Length=0 when no entry is made
>Performing Physician's Name	(0008,1050)	2C(2)	Length=0 when no entry is made
>Operator's Name	(0008,1070)	2C(2)	Always set, length=0
>Protocol Name	(0018,1030)	1C(1)	Always set
>Series Instance UID	(0020,000E)	1C(1)	Always set
>Referenced Image Sequence	(0008,1140)	2C	Length=0 when no entry is made
>>Referenced SOP Class UID	(0008,1150)	1C	Set if sequence item is present
>>Referenced SOP Instance UID	(0008,1155)	1C	Set if sequence item is present

>Referenced Standalone SOP Instance Sequence	(0040,0220)	2C	Always set, length=0
--	-------------	----	----------------------

\*1) Requirement Type Final State

### 11.3.3. Radiation Dose Module

*Table 11-9*

Attribute Name	Tag	Type	Attribute Description
Total Time of Fluoroscopy	(0040,0300)	3	Not set when no entry is made
Total Number of Exposures	(0040,0301)	3	Not set when no entry is made
Distance Source to Entrance	(0040,0306)	3	Not set when no entry is made
Entrance Dose	(0040,0302)	3	Not set when no entry is made
Exposed Area	(0040,0303)	3	Not set when no entry is made
Image Area Dose Product	(0018,115E)	3	Not set when no entry is made
Comments on Radiation Dose	(0040,0310)	3	Not set when no entry is made

### 11.3.4. Billing and Material Management Codes Module

*Table 11-10*

Attribute Name	Tag	Type	Attribute Description
Billing Procedure Step Sequence	(0040,0320)	3	Length=0 when no entry is made
>Code Value	(0008,0100)	1C	Set if sequence item is present
>Coding Scheme Designator	(0008,0102)	1C	Set if sequence item is present
>Coding Scheme Version	(0008,0103)	3	Not set when no entry is made
>Code Meaning	(0008,0104)	3	Not set when no entry is made
Film Consumption Sequence	(0040,0321)	3	Not set when no data is available
>Number of Films	(2100,0170)	3	Not set when no data is available
>Medium Type	(2000,0030)	3	Not set when no data is available
>Film Size ID	(2010,0050)	3	Not set when no data is available
Billing Supplies and Devices Sequence	(0040,0324)	3	Length=0 when no entry is made
>Quality Sequence	(0040,0293)	3	Not set when no data is available
>>Quality	(0040,0294)	3	Not set when no data is available
>>Measuring Units Sequence	(0040,0295)	3	Not set when no data is available
>>>Code Value	(0008,0100)	1C	Set if sequence item is present
>>>Coding Scheme Designator	(0008,0102)	1C	Set if sequence item is present
>>>Coding Scheme Version	(0008,0103)	3	Not set when no entry is made
>>>Code Meaning	(0008,0104)	3	Not set when no entry is made
>Billing Item Sequence	(0040,0296)	3	Not set when no data is available
>>Code Value	(0008,0100)	1C	Set if sequence item is present
>>Coding Scheme Designator	(0008,0102)	1C	Set if sequence item is present

>>Coding Scheme Version	(0008,0103)	3	Not set when no entry is made
>>Code Meaning	(0008,0104)	3	Not set when no entry is made



## 12. DIMSE-Service and Attributes

### 12.1. DIMSE-Services

*Table 12-1*

SOP Class	DIMSE Service Element	Reference	Usage SCU <sup>*1</sup>
Basic Film Session SOP Class	N-CREATE	12.2.1	M
	N-SET	not used	U
	N-DELETE	12.2.2	U
	N-ACTION	not used	U
Basic Film Box SOP Class	N-CREATE	12.3.1	M
	N-SET	not used	U
	N-DELETE	12.3.2	U
	N-ACTION	used	M
Basic Grayscale Image Box SOP Class	N-SET	12.4.1	M
Printer SOP Class	N-EVENT-REPORT	12.5.1	M
	N-GET	12.5.2	U
Print Job SOP Class	N-EVENT-REPORT	12.6.1	M
	N-GET	not used	U

\*1 : M = Mandatory, U = User option

## 12.2. Basic Film Session SOP Class

### 12.2.1. N-CREATE Attributes

The basic Film Session refers to one or more Basic Film Boxes and that are printed on one hardcopy printer. DICOM Print application supports the following DIMSE Service Elements for the Basic Film Session SOP class as SCU:

**Table 12-2**

Attribute Name	Tag	Usage	Attribute Description
Number of Copies	(2000,0010)	U	Always set ("1" - "99")
Media Type	(2000,0030)	U	Always set ("PAPER"/"CLEAR FILM"/"BLUE FILM")
Film Destination	(2000,0040)	U	Always set ("MAGAZINE"/"PROCESSOR")

### 12.2.2. N-DELETE Attributes

The affected SOP Instance UID received in N\_CREATE\_RSP message from SCP will be saved internally and used for later requests like N\_DELETE\_RQ on the Basic Film Session SOP class.

**Table 12-3**

Attribute Name	Tag	Attribute Description
Requested SOP Instance UID	(0008,0018)	Affected SOP Instance UID of N_CREATE_RSP on Basic Film Session

## 12.3. Basic Film Box SOP Class

### 12.3.1. N-CREATE Attributes

**Table 12-4**

Attribute Name	Tag	Usage	Attribute Description
Image Display Format	(2010,0010)	M	Always set ("STANDARD\1,1")
Referenced Film Session Sequence	(2010,0500)	M	Always set
>Referenced SOP Class UID	(0008,1150)	M	Always set
>Referenced SOP Instance UID	(0008,1155)	M	Always set
Film Orientation	(2010,0040)	M	Always set ("PORTRAIT")
Film Size ID	(2010,0050)	M	Always set
Magnification Type	(2010,0060)	M	Always set ("BILINEAR"/"CUBIC"/"NONE"/"REPLICATE")
Max Density	(2010,0130)	U	Always set
Min Density	(2010,0120)	U	Always set

### 12.3.2. N-DELETE Attributes

The affected SOP Instance UID received in N\_CREATE\_RSP message from SCP will be saved internally and used for later requests like N\_DELETE\_RQ on the Basic Film Box SOP class.

**Table 12-5**

Attribute Name	Tag	Attribute Description
Requested SOP Instance UID	(0008,0018)	Affected SOP Instance UID of N_CREATE_RSP on Basic Film Box

## 12.4. Basic Grayscale Image Box SOP Class

### 12.4.1. N-SET Attributes

**Table 12-6**

Attribute Name	Tag	Usage	Attribute Description
Image Position	(2020,0010)	M	Always set (0x0001)
Basic Grayscale Image Sequence	(2020,0110)	M	Always set
>Samples Per Pixel	(0028,0002)	M	Always set (0x0001)
>Photometric Interpretation	(0028,0004)	M	Always set ("MONOCHROME2")
>Rows	(0028,0010)	M	Always set
>Columns	(0028,0011)	M	Always set
>Pixel Aspect Ratio	(0028,0034)	M	Always set
>Bits Allocated	(0028,0100)	M	Always set (0x0008)
>Bits Stored	(0028,0101)	M	Always set (0x0008)
>High Bit	(0028,0102)	M	Always set (0x0007)
>Pixel Representation	(0028,0103)	M	Always set (0x0000)
>Pixel Data	(7FE0,0010)	M	Always set

## 12.5. Printer SOP Class

### 12.5.1. N-EVENT-REPORT

**Table 12-7**

Event Type Name	Event Type ID	Attribute	Tag	Usage SCU
NORMAL	1			
WARNING	2	Printer Status Information	(2110,0020)	U
FAILURE	3	Printer Status Information	(2110,0020)	U

### 12.5.2. N-GET Attributes

**Table 12-8**

Attribute Name	Tag	Usage SCP
Printer Status	(2110,0010)	M
Printer Status Information	(2110,0020)	M

## 12.6. Print Job SOP Class

### 12.6.1. N-EVENT-REPORT

The Print Job SOP Class is the possibility to monitor the execution of the print process.

DICOM Print application supports the optional N-EVENT Report DIMSE service to receive the changes of the print job status in an asynchronous way.

It can receive Events from the Print SCP asynchronously. The following information is supported.

**Table 12-9**

Event type name	Event	Attributes	Tag	Usage SCU
Normal	1	Execution Status Info	(2100,0030)	U
		Print Job ID	(2100,0010)	- (Print Queue Management SOP Class not supported)
		Film Session Label	(2000,0050)	U
		Printer Name	(2110,0030)	U
Printing	2	Execution Status Info	(2100,0030)	U
		Print Job ID	(2100,0010)	- (Print Queue Management SOP Class not supported)
		Film Session Label	(2000,0050)	U
		Printer Name	(2110,0030)	U
Done	3	Execution Status Info	(2100,0030)	U
		Print Job ID	(2100,0010)	- (Print Queue Management SOP Class not supported)
		Film Session Label	(2000,0050)	U
		Printer Name	(2110,0030)	U
Failure	4	Execution Status Info	(2100,0030)	U
		Print Job ID	(2100,0010)	- (Print Queue Management SOP Class not supported)
		Film Session Label	(2000,0050)	U
		Printer Name	(2110,0030)	U

## 13. Query Attributes

### 13.1. Patient Root Information Model

**Table 13-1 Patient level attributes, Patient Root Information Model**

Attribute name	Tag	Type	Matching
Patient name	(0010,0010)	R	single value, wildcard, universal
Patient id	(0010,0020)	U	single value, wildcard, universal
Patient's birth date	(0010,0030)	O	single value, range, universal
Patient's birth time	(0010,0032)	O	single value, range, universal
Patient's sex	(0010,0040)	O	single value, wildcard, universal
Ethnic group	(0010,2160)	O	single value, wildcard, universal
Patient comments	(0010,4000)	O	wildcard, universal
Number of Patient related studies	(0020,1200)	O	universal
Number of Patient relates series	(0020,1202)	O	universal
Number of Patient related instances	(0020,1204)	O	universal

**Table 13-2 Study level attributes, Patient Root Information Model**

Attribute name	Tag	Type	Matching
Study instance UID	(0020,000D)	U	single value,list of UIDs
Study id	(0020,0010)	R	single value, wildcard, universal
Study date	(0008,0020)	R	single value, range, universal
Study time	(0008,0030)	R	single value, range, universal
Accession number	(0008,0050)	R	single value, wildcard, universal
Referring physician's name	(0008,0090)	O	single value, wildcard, universal
Study description	(0008,1030)	O	single value, wildcard, universal
Admitting diagnoses description	(0008,1080)	O	single value, wildcard, universal
Patient's age	(0010,1010)	O	single value, wildcard, universal
Patient's size	(0010,1020)	O	single value, universal
Patient's weight	(0010,1030)	O	single value, universal
Occupation	(0010,2180)	O	single value, wildcard, universal
Additional patient history	(0010,21B0)	O	wildcard, universal
Name of physician reading study	(0008,1060)	O	single value, wildcard, universal
Modalities in Study	(0008,0061)	O	multiple values, universal
Number of study related series	(0020,1206)	O	universal
Number of study related instances	(0020,1208)	O	universal

**Table 13-3 Series level attributes, Patient Root Information Model**

Attribute name	Tag	Type	Matching
Series instance UID	(0020,000E)	U	single value,list of UID

Series number	(0020,0011)	R	single value, universal
Modality	(0008,0060)	R	single value, wildcard, universal
Laterality	(0020,0060)	O	single value, wildcard, universal
Body part examined	(0018,0015)	O	single value, wildcard, universal
Patient position	(0018,5100)	O	single value, wildcard, universal
Smallest pixel value in series	(0028,0108)	O	single value, universal
Largest pixel value in series	(0028,0109)	O	single value, universal
Protocol name	(0018,1030)	O	single value, wildcard, universal
Series date	(0008,0021)	O	single value, range, universal
Series time	(0008,0031)	O	single value, range, universal
Series description	(0008,103E)	O	single value, wildcard, universal
Operators name	(0008,1070)	O	single value, wildcard, universal
Performing physician's name	(0008,1050)	O	single value, wildcard, universal
Performed procedure step start date	(0040,0244)	O	universal
Performed procedure step start time	(0040,0245)	O	universal
Number of series related instances	(0020,1209)	O	universal

**Table 13-4 Image level attributes, Patient Root Information Model**

Attribute name	Tag	Type	Matching
SOP instance UID	(0008,0018)	U	single value, list of UID
Image number	(0020,0013)	R	single value, universal
Image date	(0008,0023)	O	single value, range, universal
Image time	(0008,0033)	O	single value, range, universal
Modality	(0008,0060)	O	single value, wildcard, universal
Image comments	(0020,4000)	O	universal

## 13.2. Study Root Information Model

**Table 13-5 Study level attributes, Study Root Information Model**

Attribute name	Tag	Type	Matching
Patient name	(0010,0010)	R	single value, wildcard, universal
Patient id	(0010,0020)	R	single value, wildcard, universal
Patient's birth date	(0010,0030)	O	single value, range, universal
Patient's birth time	(0010,0032)	O	single value, range, universal
Patient's sex	(0010,0040)	O	single value, wildcard, universal
Patient comments	(0010,4000)	O	wildcard, universal
Number of Patient related studies	(0020,1200)	O	universal
Number of Patient relates series	(0020,1202)	O	universal
Number of Patient related instances	(0020,1204)	O	universal

Study instance UID	(0020,000D)	U	single value, list of UIDs
Study id	(0020,0010)	R	single value, wildcard, universal
Study date	(0008,0020)	R	single value, range, universal
Study time	(0008,0030)	R	single value, range, universal
Accession number	(0008,0050)	R	single value, wildcard, universal
Referring physician's name	(0008,0090)	O	single value, wildcard, universal
Study description	(0008,1030)	O	single value, wildcard, universal
Admitting diagnoses description	(0008,1080)	O	single value, wildcard, universal
Patient's age	(0010,1010)	O	single value, wildcard, universal
Patient's size	(0010,1020)	O	single value, universal
Patient's weight	(0010,1030)	O	single value, universal
Occupation	(0010,2180)	O	single value, wildcard, universal
Additional patient history	(0010,21B0)	O	wildcard, universal
Name of physician reading study	(0008,8060)	O	single value, wildcard, universal
Modalities in Study	(0008,0061)	O	multiple values, universal
Number of study related series	(0020,1206)	O	universal
Number of study related instances	(0020,1208)	O	universal

**Table 13-6 Series level attributes, Study Root Information Model**

Attribute name	Tag	Type	Matching
Series instance UID	(0020,000E)	U	single value, list of UID
Series number	(0020,0011)	R	single value, universal
Modality	(0008,0060)	R	single value, wildcard, universal
Laterality	(0020,0060)	O	single value, wildcard, universal
Body part examined	(0018,0015)	O	single value, wildcard, universal
Patient position	(0018,5100)	O	single value, wildcard, universal
Smallest pixel value in series	(0028,0108)	O	single value, universal
Largest pixel value in series	(0028,0109)	O	single value, universal
Protocol name	(0018,1030)	O	single value, wildcard, universal
Series date	(0008,0021)	O	single value, range, universal
Series time	(0008,0031)	O	single value, range, universal
Series description	(0008,103E)	O	single value, wildcard, universal
Operators name	(0008,1070)	O	single value, wildcard, universal
Performing physician's name	(0008,1050)	O	single value, wildcard, universal
Performed procedure step start date	(0040,0244)	O	universal
Performed procedure step start time	(0040,0245)	O	universal
Number of series related instances	(0020,1209)	O	universal

**Table 13-7 Image level attributes, Study Root Information Model**

Attribute name	Tag	Type	Matching
----------------	-----	------	----------

SOP instance UID	(0008,0018)	U	single value, list of UID
Image number	(0020,0013)	R	single value, universal
Image date	(0008,0023)	O	single value, range, universal
Image time	(0008,0033)	O	single value, range, universal
Modality	(0008,0060)	O	single value, wildcard, universal
Image comments	(0020,4000)	O	universal